



STA529

2 x 100 mW class-D amplifier with analog or digital input
2.0 multichannel digital audio processor with FFX

Features

- Up to 96 dB dynamic range
- Sample rates from 8 kHz to 192 kHz
- FFX™ class-D driver
- 1.5 V to 1.95 V digital power supply
- 1.5 V to 1.95 V analog power supply
- 18-bit audio processing and class-D FFX™ modulator
- Digital volume control:
 - +36 dB to 105 dB in 0.5 dB steps
 - Software volume update
- Individual channel and master gain/attenuation
- Automatic invalid input detect mute
- 2-channel I²S input/output data interface
- Digitally controlled POP-free operation
- Input and output channel mapping
- 250 mΩ output CMOS R_{dson}
- > 90% efficiency
- Stereo headphone plus mono speaker application:
 - 50 mW stereo into 32 Ω headphone
 - 100 mW stereo into 16 Ω headphone

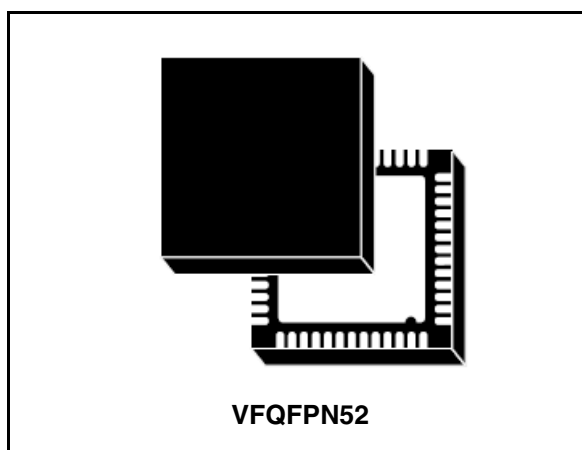
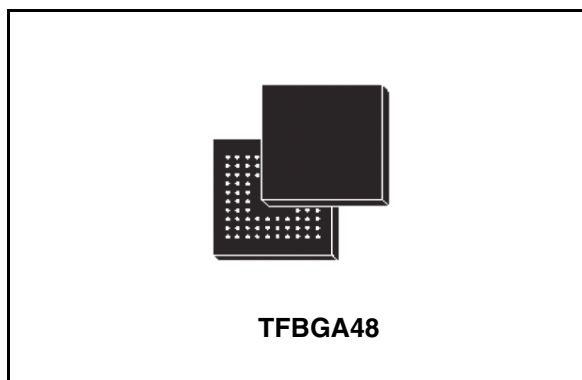

Order codes

Part number	Package
STA529B	TFBGA48 (tube)
STA529Q	VFQFPN52 (tube)

Contents

- 1 Introduction 4**
- 2 Connection diagrams and pin descriptions 5**
 - 2.1 TFBGA48 package 5
 - 2.1.1 Connection diagram 5
 - 2.1.2 Pin description 6
 - 2.1.3 Thermal data 7
 - 2.2 VFQFPN52 package 8
 - 2.2.1 Connection diagram 8
 - 2.2.2 Pin description 9
- 3 Electrical specifications 11**
 - 3.1 Maximum and recommended operating conditions 11
 - 3.2 Electrical characteristics 12
 - 3.3 Lock time 13
 - 3.4 ADC performance values 14
- 4 Digital processing 15**
 - 4.1 Signal processing flow 15
 - 4.2 I²C interface disabled 15
 - 4.3 Volume control and gain 16
- 5 PLL 17**
 - 5.1 Functional description 18
 - 5.2 Configuration examples 19
- 6 ADC 22**
 - 6.1 Functional description 22
 - 6.1.1 Digital filter characteristics 22
 - 6.1.2 High-pass filter characteristics 23
 - 6.1.3 Programmable gain amplifier 23
 - 6.2 Application scheme 23
 - 6.3 Configuration examples 24

7	Driver configuration	25
7.1	I ² S bypass	25
8	Serial audio interface	26
8.1	Specifications	26
8.2	Master mode	27
8.3	Slave mode	28
8.4	Serial formats	29
8.4.1	DSP	30
8.4.2	I ² S	30
8.4.3	PCM/IF (non-delayed mode)	31
8.4.4	PCM/IF (delayed mode)	31
9	I²C interface	32
9.1	Data transition and change	32
9.2	Start condition	32
9.3	Stop condition	32
9.4	Data input	32
9.5	Device addressing	32
9.6	Write operation	33
9.6.1	Byte write	33
9.6.2	Multi-byte write	33
9.7	Read operation	33
9.7.1	Current address byte read	33
9.7.2	Current address multi-byte read	33
9.7.3	Random address byte read	33
9.7.4	Random address multi-byte read	34
10	Registers	35
10.1	Summary	35
10.2	General registers	36
11	Package information	53
11.1	Package TFBGA48	53
11.2	Package VFQFPN52	55
12	Revision history	57

1 Introduction

The STA529 is a digital stereo class-D audio amplifier. It includes an audio DSP, a ST proprietary high-efficiency class-D driver and CMOS power output stage. It is intended for high-efficiency digital-to-power-audio conversion for portable applications. The STA529 also provides output capabilities for FFX™. In conjunction with a power device, the STA529 provides high-quality digital amplification.

The STA529 contains an on-chip volume/gain control.

The PWM amplifier achieves greater than 90% efficiency for longer battery life for portable systems.

The innovative class-D modulation, allows the STA529 to work without external LC filters and without a heatsink.

The STA529 I2CDIS pin disables the audio DSP functions to provide a direct conversion of the input signal into output power (the I²C interface is disabled). This conversion is done without the microcontroller.

The STA529 is designed for low-power operation with extremely low-current consumption in standby mode. It is available in two packages: the TFBGA48 and the VFQFPN52. These are very thin packages (1.2 mm thick) intended for small portable applications.

Figure 1. Block diagram

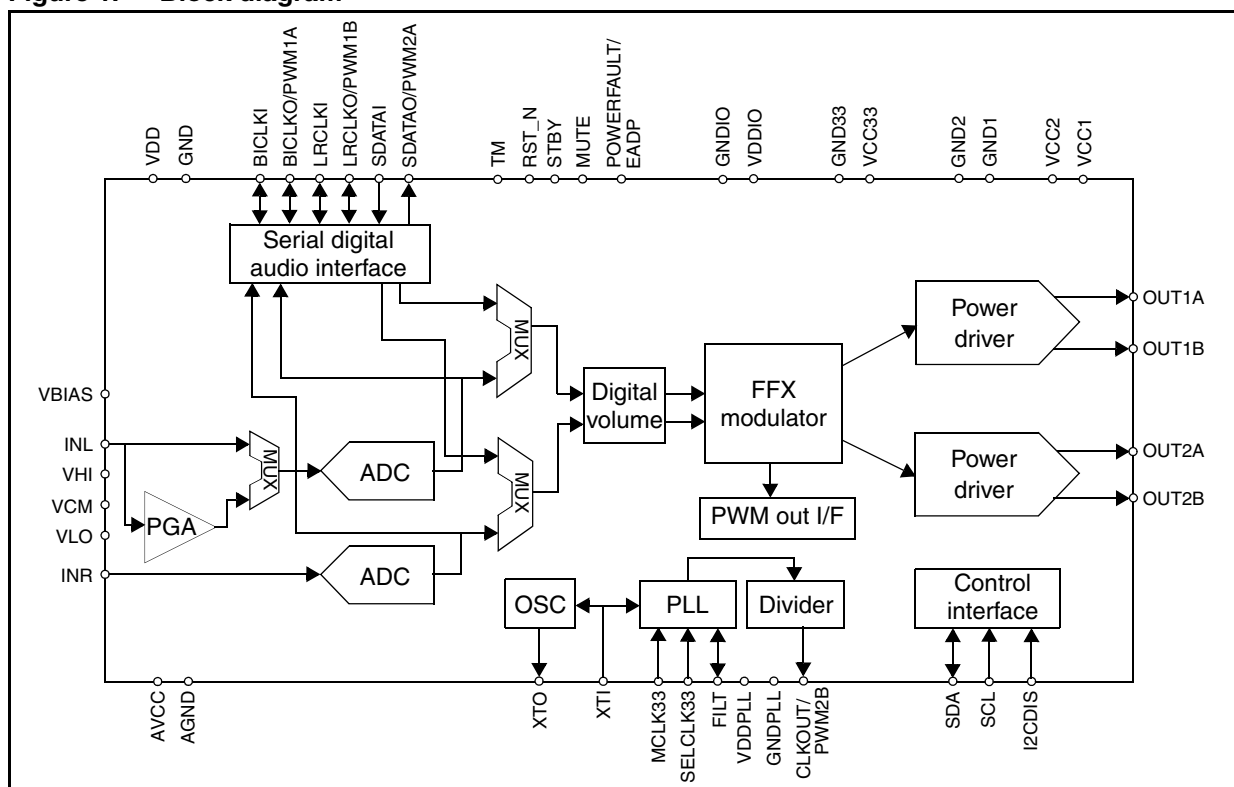

2 Connection diagrams and pin descriptions

This section includes connection diagrams and pin descriptions for the following packages:

- TFBGA48
- VFQFPN52

2.1 TFBGA48 package

2.1.1 Connection diagram

Figure 2 shows the connection diagram for the TFBGA48 package.

Figure 2. Package: TFBGA48

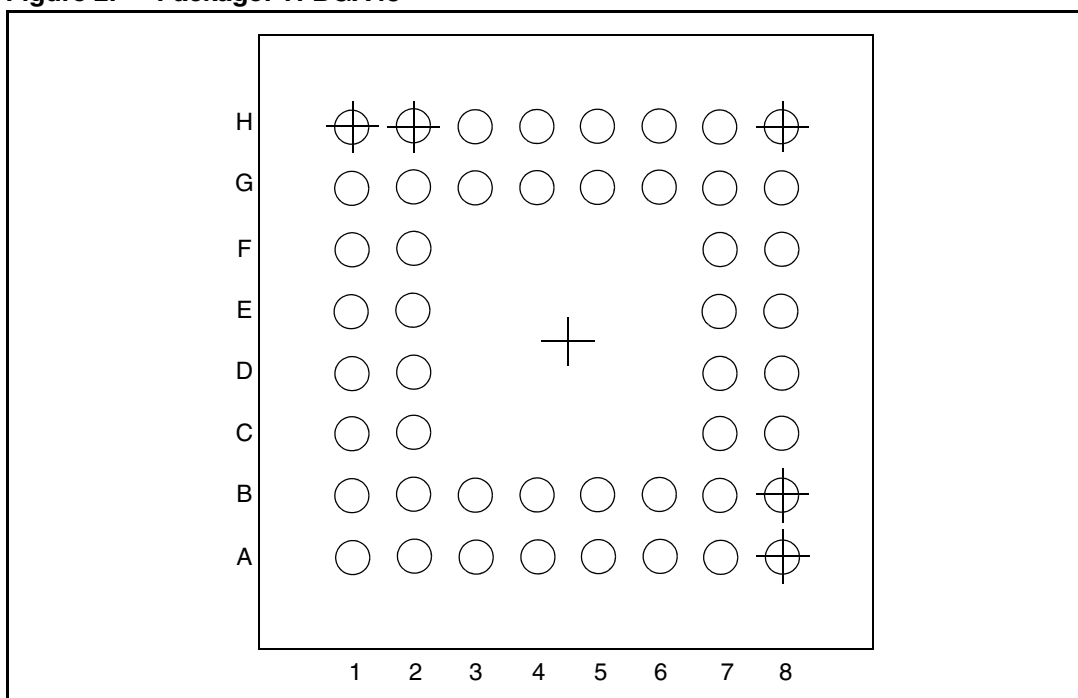

2.1.2 Pin description

Table 1. Package: TFBGA48

Pin #	Name	Type	Description
D7	RST_N	Digital input	Reset (active low)
D1	XTI	Digital input	Crystal input or master clock input
E1	MCLK33	Digital input	Master clock input 3.3 V capable XTI: crystal input or master clock input 3.3 V capable
G3	SELCLK33	Digital input	Master clock input selector: SELCLK33 = 1 -> MCLK33 selected SELCLK33 = 0 -> XTI selected
D2	XTO	Digital output	Crystal output
C7	CLKOUT/ PWM2B	Digital output	Buffered clock output / PWM2B FFX TM
F1	SCL	Digital input	I ² C serial clock
G1	SDA	Digital input/output	I ² C serial data
G2	I2CDIS	Digital input	I ² C disable pin (active high)
G8	STBY	Digital input	Standby (active high)
B7	MUTE	Digital input	Mute (active high)
H6	BICLKI	Digital input/output	Input serial audio interface bit-clock
H5	LRCLKI	Digital input/output	Input serial audio interface L/R-clock
E2	SDATAI	Digital input	Input serial audio interface data
G6	BICLKO/ PWM1A	Digital input/output	Output serial audio interface bit-clock (volume DOWN when I2CDIS = 1) / PWM1A FFX TM
G5	LRCLKO/ PWM1B	Digital input/output	Output serial audio interface L/R-clock (volume UP when I2CDIS = 1) / PWM1B FFX TM
G4	SDATAO/ PWM2A	Digital output	Output serial audio interface data / PWM2A FFX TM
H2	TM	Digital input	Test mode (active high)
H7	INL	Analog input	ADC left channel line input or microphone input
H8	INR	Analog input/output	ADC right channel line input
G7	VBIAS	Analog input/output	ADC microphone bias voltage
D8	VCM	Analog input/output	ADC common mode voltage
F8	AVDD	Supply	ADC analog supply
E8	AGND	Ground	ADC analog ground

Table 1. Package: TFBGA48 (continued)

Pin #	Name	Type	Description
F7	VHI	Analog input	ADC high reference voltage
E7	VLO	Analog input	ADC low reference voltage
H1	FILT	Analog input/output	PLL loop filter terminal
H4	VDDPLL	Supply	PLL analog supply
H3	GNDPLL	Ground	PLL analog ground
A6	OUT1A	Analog output	Channel 1 half-bridge A output
B6	OUT1A	Analog output	Channel 1 half-bridge A output
A5	OUT1B	Analog output	Channel 1 half-bridge B output
B5	OUT1B	Analog output	Channel 1 half-bridge B output
A3	OUT2A	Analog output	Channel 2 half-bridge A output
B3	OUT2A	Analog output	Channel 2 half-bridge A output
A4	OUT2B	Analog output	Channel 2 half-bridge B output
B4	OUT2B	Analog output	Channel 2 half-bridge B output
F2	POWERFAULT/ EADP	Digital output	Power fault signal (active high) / external audio power-down signal
A8	VCC1	Supply	Channel 1 power supply
A1	VCC2	Supply	Channel 2 power supply
A7	GND1	Ground	Channel 1 power ground
A2	GND2	Ground	Channel 2 power ground
C2	VCC33	Supply	Pre-driver supply
B2	GND33	Ground	Pre-driver ground
C8	VDD	Supply	Digital supply
B8	GND	Ground	Digital ground
C1	VDDIO	Supply	I/O ring supply
B1	GNDIO	Ground	I/O ring ground

2.1.3 Thermal data

[Table 2](#) gives the thermal resistance specifications for the TFBGA48 and the VFQFPN52.

Table 2. Thermal data

Device	Parameter	Min	Typ	Max	Unit
TFBGA48	Thermal resistance junction to ambient		72		°C/W
VFQFPN52	Thermal resistance junction to ambient		22		°C/W

2.2 VFQFPN52 package

2.2.1 Connection diagram

Figure 3 shows the connection diagram for the VFQFPN52 package.

Figure 3. Package: VFQFPN52

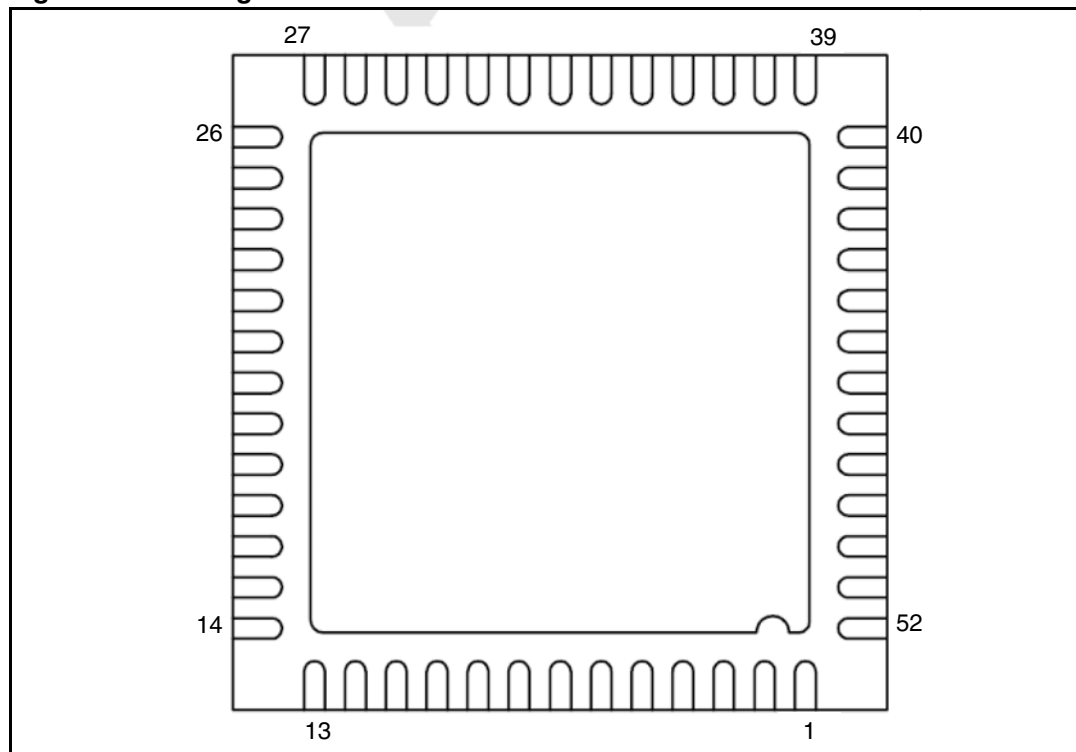

2.2.2 Pin description

Table 3. Package: VFQFPN52

Pin #	Name	Type	Description
10	RST_N	Digital input	Reset (active low)
38	XTI	Digital input	Crystal input or master clock input
37	MCLK33	Digital input	Master clock input 3.3 V capable XTI: crystal input or master clock input 3.3 V capable
36	SELCLK33	Digital input	Master clock input selector: SELCLK33 = 1 -> MCLK33 selected SELCLK33 = 0 -> XTI selected
39	XTO	Digital output	Crystal output
11	CLKOUT	Digital output	Buffered clock output
34	SCL	Digital input	I ² C serial clock
35	SDA	Digital input/output	I ² C serial data
33	I2CDIS	Digital input	I ² C disable pin (active high)
1	STBY	Digital input	Standby (active high)
14	MUTE	Digital input	Mute (active high)
51	BICLKI	Digital input/output	Input serial audio interface bit-clock
47	LRCLKI	Digital input/output	Input serial audio interface L/R-clock
45	SDATAI	Digital input	Input serial audio interface data
52	BICLKO	Digital input/output	Output serial audio interface bit-clock (volume DOWN when I2CDIS=1)
48	LRCLKO	Digital input/output	Output serial audio interface L/R-clock (volume UP when I2CDIS=1)
46	SDATAO	Digital output	Output serial audio interface data
32	TM	Digital input	Test mode (active high)
2	INL	Analog input	ADC left channel line input or microphone input
3	INR	Analog input/output	ADC right channel line input
4	VBIAS	Analog input/output	ADC microphone bias voltage
9	VCM	Analog input/output	ADC Common mode voltage
5	AVDD	Supply	ADC analog supply
8	AGND	Ground	ADC analog ground
6	VHI	Analog input	ADC High reference voltage

Table 3. Package: VFQFPN52 (continued)

Pin #	Name	Type	Description
7	VLO	Analog input	ADC Low reference voltage
40	FILT	Analog input/output	PLL loop filter terminal
42	VDDPLL	Supply	PLL analog supply
41	GNDPLL	Ground	PLL analog ground
16	OUT1A	Analog output	Channel 1 half-bridge A output
19	OUT1B	Analog output	Channel 1 half-bridge B output
25	OUT2A	Analog output	Channel 2 half-bridge A output
22	OUT2B	Analog output	Channel 2 half-bridge B output
31	POWERFAULT/ EADP	Digital output	Power fault signal (active high)/external audio power down signal
15	VCC1A	Supply	Channel 1 half-bridge A power supply
20	VCC1B	Supply	Channel 1 half-bridge B power supply
26	VCC2A	Supply	Channel 2 half-bridge A power supply
21	VCC2B	Supply	Channel 2 half-bridge B power supply
17	GND1A	Ground	Channel 1 half-bridge A power ground
18	GND1B	Ground	Channel 1 half-bridge B power ground
24	GND2A	Ground	Channel 2 half-bridge A power ground
23	GND2B	Ground	Channel 2 half-bridge B power ground
30	VCC33	Supply	Pre-driver supply
27	GND33	Ground	Pre-driver ground
13	VDD1	Supply	Digital supply
12	GND1	Ground	Digital ground
44	VDD2	Supply	Digital supply
43	GND2	Ground	Digital ground
29	VDDIO1	Supply	I/O ring supply
28	GNDIO1	Ground	I/O ring ground
50	VDDIO2	Supply	I/O ring supply
49	GNDIO2	Ground	I/O ring ground

3 Electrical specifications

This section includes the electrical specifications for the STA529.

3.1 Maximum and recommended operating conditions

[Table 4](#) provides the maximum ratings and [Table 5](#) the recommended operating conditions.

Table 4. Absolute maximum ratings

Signal	Description	Min	Max	Unit
VDD/VDD1/VDD2	Digital supply voltage	-0.5	+2.5	V
AVDD	ADC supply voltage	-0.5	+4	V
VDDPLL	PLL analog supply voltage	-0.5	+2.5	V
VCC1A/1B/2A/2B	Power stage supply voltage	-0.5	+4	V
VCC33	Pre-driver supply	-0.5	+4	V
VDDIO	Digital I/O supply	-0.5	+4	V
V _{DI}	Voltage range digital in	-0.5	VDDIO +0.3	V
V _{AI}	Voltage range analog in	-0.5	AVDD +0.3	V
V _o	Voltage on output pins	-0.5	VDDIO +0.3	V
T _{STG}	Storage temperature	-40	150	°C
T _{AMB}	Ambient operating temperature	-20	85	°C

Note: All grounds must be within 0.3 V of each other.

Table 5. Recommended operating conditions

Symbol	Parameter	Min	Typ	Max	Unit
VDD/VDD1/VDD2	Digital supply voltage	1.55	1.8	1.95	V
AVDD	ADC supply voltage	1.8	3.3	3.6	V
VDDPLL	PLL analog supply voltage	1.55	1.8	1.95	V
VCC1A/1B/2A/2B	Power stage supply voltage	1.8	3.3	3.6	V
VCC33	Pre-driver supply	1.8	3.3	3.6	V
GND1, GND2, GND33	Channel 1 and 2 power ground, pre-driver ground		0		
T _{AMB}	Ambient operating temperature	0	25	70	°C

3.2 Electrical characteristics

Table 6 lists the device's electrical characteristics (see also *Table 5* for supply voltages).

Table 6. Electrical characteristics

Symbol	Parameter	Test conditions	Min	Typ	Max	Unit
Eff	Output power efficiency			90		%
R_{dson}	Output stage N/PMOS on-resistance			250		m Ω
IstbyL	Logic power supply current at standby			1.3		μ A
IstbyP	Bridges power supply current in standby			0.7		μ A
IddL	Logic power supply current at operating			15		mA
IddP	Bridges power supply current at operating			0.5		mA
Tds	Low current dead time (static)			1		ns
Tdd	High current dead time (dynamic)			2.5		ns
Tr	Rise time			3		ns
Tf	Fall time			3		ns
THDN	Total harmonic distortion	0 dBFS input, 32 Ω load headphone		0.1		%
THDN	Total harmonic distortion	-6 dBFS input, 32 Ω load headphone		0.05		%

Note: *LRCLKI* frequency (F_s) = 48 kHz, input frequency = 1 kHz, and R_{load} = 32 Ω unless otherwise specified.

The following tables give the distortion values for headphones and speakers.

Table 7. Load power at 1% distortion headphone mode

Load (Ω)	P (mW) at 1.8 V	P (mW) at 3.3 V	P (mW) at 3.6 V
16	20	70	80
32	10	32	40

3.3 Lock time

[Table 8](#) gives the typical lock time of the PLL using the suggested loop filter, 1.8 V supply voltage and 30 °C junction temperature.

Table 8. PLL lock time

Parameter	Value
Lock time	200 μ s

3.4 ADC performance values

Table 9. Programmable gain performance

Parameter	Min	Typ	Max	Unit
Dynamic range 1 kHz 1.8 V supply				dB
Dynamic range 1 kHz 1.8 V supply A-weighted		84		dB
SNDR 1 kHz 1.8 V supply				dB
SNDR 1 kHz 1.8 V supply A-weighted		84		dB
THD 1 kHz (-1 dB input) 1.8 V supply		75		dB
Deviation from linear phase				degree
Pass band				kHz
Pass band ripple				dB
Stop band				kHz
Stop band attenuation				dB
Group delay 8 kHz				ms
Group delay 48 kHz				ms
Cross talk 1.8 V				dB
Cross talk 3.3 V				dB

4 Digital processing

The STA529 processor block is a digital block providing two channels of audio processing and channel-mapping capability.

4.1 Signal processing flow

I²S or stereo ADC data can be selected. The I²S frequency range is from 8 kHz to 192 kHz. ADC sampling frequency can be selected from 8 kHz to 48 kHz.

4.2 I²C interface disabled

When pin I2CDIS = 1, the SDA, SCL, LRCLKO and BICLK pins can be pulled high or low to change certain parameters of operation.

- SDA = 0: FFX input comes from ADC
SDA = 1: FFX input comes from digital audio interface
- SCL = 0: binary output mode (binary soft start/stop enabled)
SCL = 1: phase shift output mode
- LRCLKO = 0: no volume change
LRCLKO = 1: volume up
- BICLK = 0: no volume change
BICLK = 1: volume down

At power up, the master volume is set to -60 dB. When holding pin LRCLKO = 1 and pin BICLK = 1 simultaneously, the master volume is set to 0 dB. A high pulse on pin LRCLKO causes a master volume change of +0.5 dB and a high pulse on pin BICLK causes a master volume change of -0.5 dB.

4.3 Volume control and gain

The volume control structure of the STA529 consists of individual volume registers for each channel and a master volume register that provides an offset to each channel’s volume setting. The individual channel volumes are adjustable in 0.5 dB steps from +36 dB to -91.5 dB. As an example, if register LVOL = 0x00 or +36 dB and register MVOL = 0x18 or -12 dB, then the total gain for the left channel is +24 dB.

When the mute bit is set to 1, all channels are muted. The volume control provides a soft mute with the volume ramping down to mute in 4096 samples from the maximum volume setting at the internal processing rate (~48 kHz).

Table 10. Master volume offset as a function of register MVOL

MVOL[7:0]	Volume offset from channel value
0x00	0 dB
0x01	-0.5 dB
0x02	-1dB
...	...
0x78	-60 dB
...	...
0xFE	-105 dB
0xFF	Hard master mute

Table 11. Channel volume as a function of registers LVOL and RVOL

LVOL/RVOL[7:0]	Volume
0x00	+36 dB
0x01	+35.5 dB
0x02	+35 dB
...	...
0x47	+0.5 dB
0x48	0 dB
0x49	-0.5 dB
...	...
...	...
0xFF	-91.5 dB

5 PLL

Figure 4 shows the main components of the PLL.

Figure 4. PLL block diagram

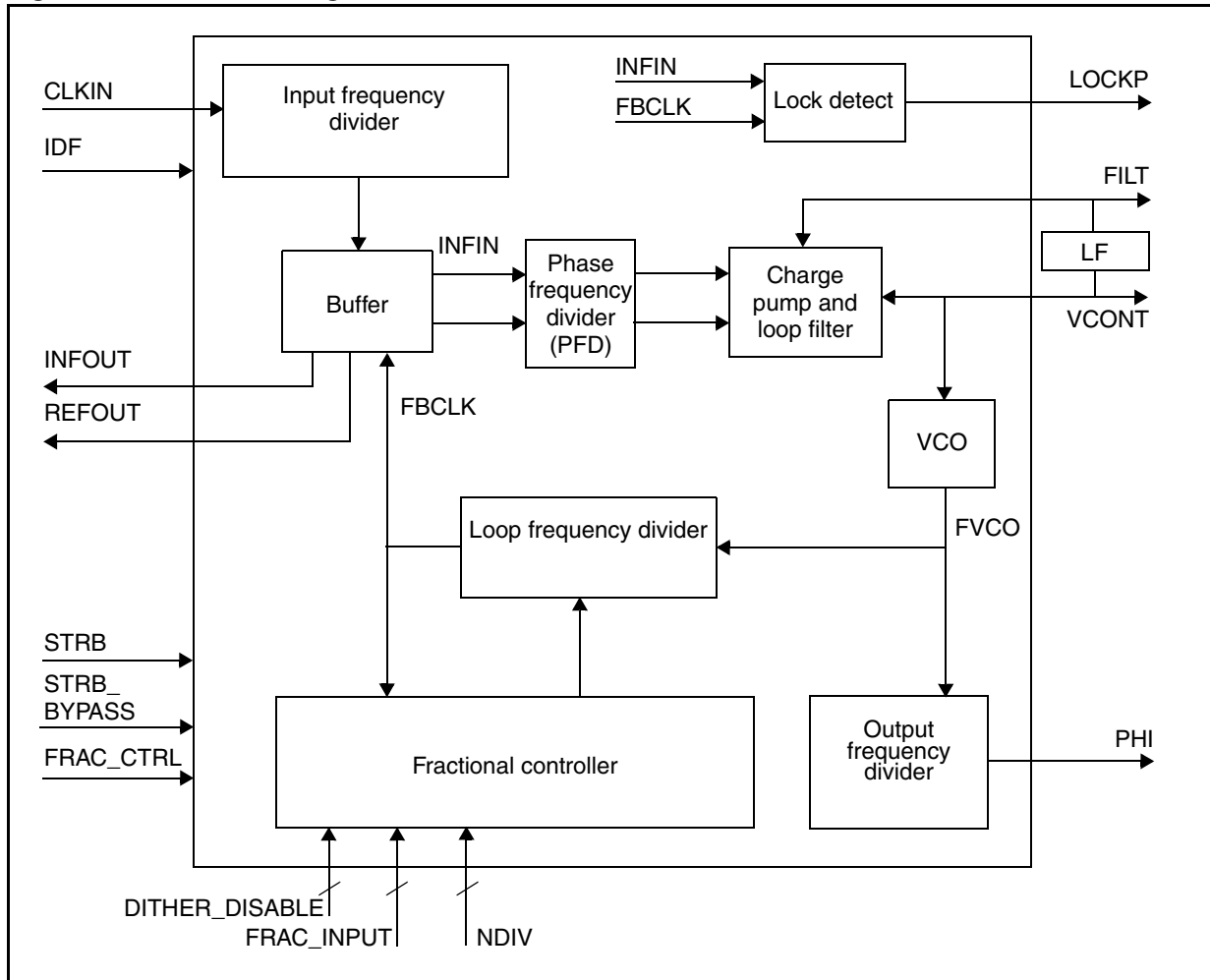

5.1 Functional description

Phase/frequency detector

The phase/frequency detector (PFD) compares the phase difference between the corresponding rising edges of INFIN and FBCLK, (clock output from the loop frequency divider) by generating voltage pulses with widths proportional to the input phase error.

Charge pump and loop filter

This block converts the voltage pulses from the phase/frequency detector to current pulses which charge the loop filter and generate the control voltage for the voltage-controlled oscillator. The loop filter is placed external to the PLL on pin FILT.

Voltage controlled oscillator

The voltage controlled oscillator (VCO) is the oscillator inside the PLL. It produces a frequency output (FVCO) proportional to the input control voltage.

Input frequency divider

This frequency divider divides the PLL input clock CLKIN by a factor called the input division factor (IDF) to generate the PFD input frequency INFIN.

Loop frequency divider

This frequency divider is present within the PLL for dividing FVCO by a factor called the loop division factor (LDF). The output of this block is the FBCLK.

Output frequency divider

The PLL output PHI is generated by dividing the FVCO by the output division factor (ODF). The divider that divides the FVCO to generate the clock to the core is called the output frequency divider. In the STA529, the ODF is fixed to be divisible by 2 and cannot be configured.

Lock-detect circuit

The output of this block (the LOCKP signal) is asserted high when the PLL enters the state of COARSE LOCK in which the output frequency is within +/-10% (approximately) of the desired frequency. The LOCKP signal is refreshed every 32 cycles of the INFIN. The generated value is based on the result of comparing the number of FBCLK cycles in a window of 14 INFIN cycles. The different cases generated after comparison are as follows.

- If LOCKP is already at 0, then in the next refresh cycle LOCKP goes to 1 if the number of FBCLK cycles in the 14-cycle INFIN window is 13, 14, or 15. Otherwise LOCKP stays at 0.
- If LOCKP is already at 1, then in the next refresh cycle LOCKP goes to 0 if the number of FBCLK cycles in the 25-cycle INFIN window is less than 11 or higher than 17, otherwise LOCKP stays at 1.
- If LOCKP is already at 1 and CLKIN is lost (no longer present on the input pin), LOCKP stays at 1. In this case, the PLL is unlocked.

PLL filter

Figure 5 shows the PLL filter scheme. Recommended values are $R1 = 12.5 \text{ k}\Omega$, $C1 = 250 \text{ pF}$, and $C2 = 82 \text{ pF}$.

Figure 5. PLL filter scheme

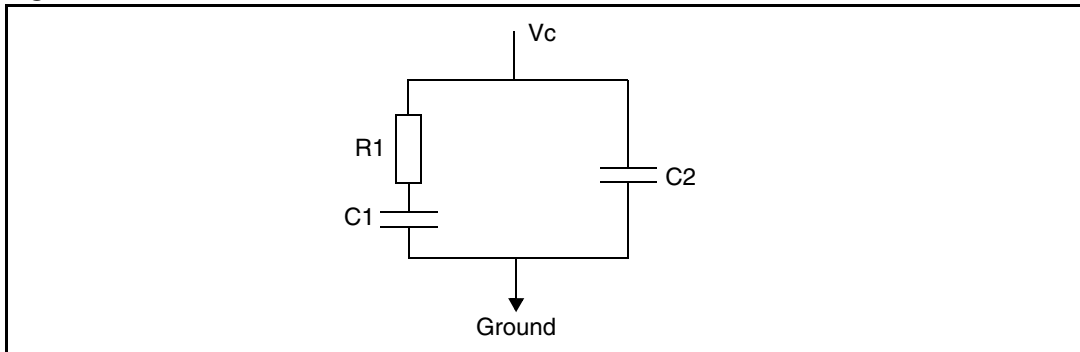

Table 8 on page 13 gives a typical lock time value for the PLL.

5.2 Configuration examples

The STA529 PLL can be configured in two ways:

- default startup configuration
- direct PLL programming

The default startup configuration reads the device's defaults. With this configuration, it is not necessary to program the PLL dividers directly as some presets are used. In this mode, the oversampling ratio between pins XTI (or MCLK33) and LRCLKI is fixed to 256.

The direct PLL programming bypasses the automatic presets allowing direct programming of the PLL dividers.

The output PLL frequency can be determined as following:

Output division factor:

$$\text{ODF} = 2$$

Relation between input and output clock frequency:

$$F_{\text{INFIN}} = F_{\text{XTI}} / \text{IDF}$$

If register bit PLLCFG0.FRAC_CTRL = 1

$$F_{\text{VCO}} = F_{\text{INFIN}} * (\text{LDF} + \text{FRACT}/2^{16} + 1/2^{17})$$

$$F_{\text{PHI}} = F_{\text{VCO}} / \text{ODF}$$

When register bit PLLCFG0.DITHER_DISABLE[1] = 1, the $1/2^{17}$ factor is not in the multiplication. This is recommended in order to keep register bit PLLCFG0.DITHER_DISABLE[1] = 0, otherwise there can be spurious signals in the output clock spectrum.

If register bit PLLCFG0.FRAC_CTRL = 0, then:

$$F_{VCO} = F_{INFIN} * LDF$$

$$F_{PHI} = F_{VCO} / ODF$$

In the above equations:

FRACT = Decimal equivalent of register bit PLLCFG1.FRAC_INPUT[15:0]

IDF = Input division factor (refer to previous formulas)

LDF = Loop division factor (refer to previous formulas)

ODF = Output division factor = 2

F_{INFIN} = INFIN frequency

F_{XTI} = XTI frequency

F_{VCO} = VCO frequency

F_{PHI} = Frequency of the PLL output clock

When selecting the value of IDF, LDF and FRACT make sure the following limits are maintained:

$$2.048 \text{ MHz} < F_{XTI} < 49.152 \text{ MHz}$$

$$2.048 \text{ MHz} < F_{INFIN} < 16.384 \text{ MHz}$$

$$65.536 \text{ MHz} < F_{VCO} < 98.304 \text{ MHz}$$

There are also some additional constraints on IDF and LDF. IDF should be greater than 0, LDF should be greater than 5 if FRAC_CTRL = 0 and greater than 8 if FRAC_CTRL = 1.

When automatic settings are not used, the PLL must be configured to generate an internal frequency of N * Fs, where Fs is the LRCLKI pin frequency. Values of N are given in [Table 12](#).

Table 12. Oversampling table

Fs (kHz)	N	F _{PHI} (MHz)
8	4096	32.768
11.025	4096	45.1584
12	4096	49.152
16	2048	32.768
22.05	2048	45.1584
24	2048	49.152
32	1024	32.768
44.1	1024	45.1584
48	1024	49.152
64	512	32.768
88.2	512	45.1584
96	512	49.152
128	256	32.768
176.4	256	45.1584
192	256	49.152

Example 1:

$$F_{XTI} = 13 \text{ MHz}$$

$$F_s = 44.1 \text{ kHz}$$

IDF should be equal to 3 otherwise LDF become less than 8 (FRAC_CTRL must be 1):

$$\text{LDF} = \text{floor}(45.1584/(13/\text{IDF})) = 10$$

$$\text{FRACT} = \text{round}([(45.1584/(13/\text{IDF})) - \text{floor}(45.1584/(13/\text{IDF}))] * 2^{16}) = 27602$$

(where:

floor: rounded towards zero

round: rounded real number to nearest integer)

Using the above configuration, the system clock is 45.15841675 MHz, the approximate static error is 16 Hz (that is, 0.5 ppm).

Example 2:

$$F_{XTI} = 19.2 \text{ MHz}$$

$$F_s = 48 \text{ kHz}$$

IDF should be equal to 4 otherwise LDF become less than 8 (FRAC_CTRL must be 1):

$$\text{LDF} = \text{floor}(49.152/(19.2/\text{IDF})) = 10$$

$$\text{FRACT} = \text{round}([(49.152/(19.2/\text{IDF})) - \text{floor}(49.152/(19.2/\text{IDF}))] * 2^{16}) = 15728$$

Using the above configuration, the system clock is 49.151953125 MHz, the approximate static error is 47 Hz (that is, 1 ppm).

6 ADC

This section describes the analog-to-digital converter (ADC).

6.1 Functional description

The STA529 analog input is provided through a low power, low voltage, stereo audio analog-to-digital converter front-end designed for audio applications. It includes a programmable gain amplifier, anti-aliasing filter, low-noise microphone biasing circuit, a third-order MASH2-1 delta-sigma modulator, digital decimating filter, and a first-order DC-removal filter. This device is fabricated using a 0.18 μm CMOS process, where high-speed precision analog circuits are combined with high-density logic circuits.

The ADC works in a microphone input (mic-in) mode and in a line-input mode.

If the line input mode is selected, the ADC is configured in stereo and all conversion channels are active.

If the microphone input mode is selected, the ADC is configured in mono. The mono channel is routed through the left conversion path, and the right conversion path is kept in power-down mode to minimize power consumption. A programmable gain amplifier (PGA) is available in mic-in mode, giving the possibility to amplify the signal from 0 to +42 dB in steps of 6 dB.

6.1.1 Digital filter characteristics

The digital filter characteristics are shown in [Table 13](#).

Table 13. Digital filter characteristics

Parameter	Typical	Unit
Passband	$0.4535 * F_s$	kHz
Passband ripple:		
Fs mode	0.08 at 44.1 kHz	dB
Fs_by_2 mode	0.08 at 22.05 kHz	dB
Fs_by_4 mode	0.08 at 11.025 kHz	dB
Stop band attenuation:		
Fs mode	45 at 44.1 kHz	dB
Fs_by_2 mode	45 at 22.05 kHz	dB
Fs_by_4 mode	45 at 11.025 kHz	dB
Group delay:		
Fs mode	0.4 at 32 kHz	ms
Fs_by_2 mode	0.7 at 16 kHz	ms
Fs_by_4 mode	1.4 at 8 kHz	ms

6.1.2 High-pass filter characteristics

Table 14. High-pass filter characteristics

Parameter	Typical	Unit
Frequency response:		
-3 dB	7	Hz
-0.08 dB	50	Hz
Phase deviation at 20 Hz	19.35	degree
Passband ripple	0.08	dB

6.1.3 Programmable gain amplifier

The programmable gain amplifier (PGA) is available in mic-in mode only. It is possible to amplify the input signal from 0 to 42 db in steps of 6 db. The setting is done through PGA bits of the ADCCFG register (see [ADCCFG on page 49](#) for details).

See [Table 9 on page 14](#) for performance values.

6.2 Application scheme

[Figure 6](#) shows the filter circuit.

Figure 6. Block diagram

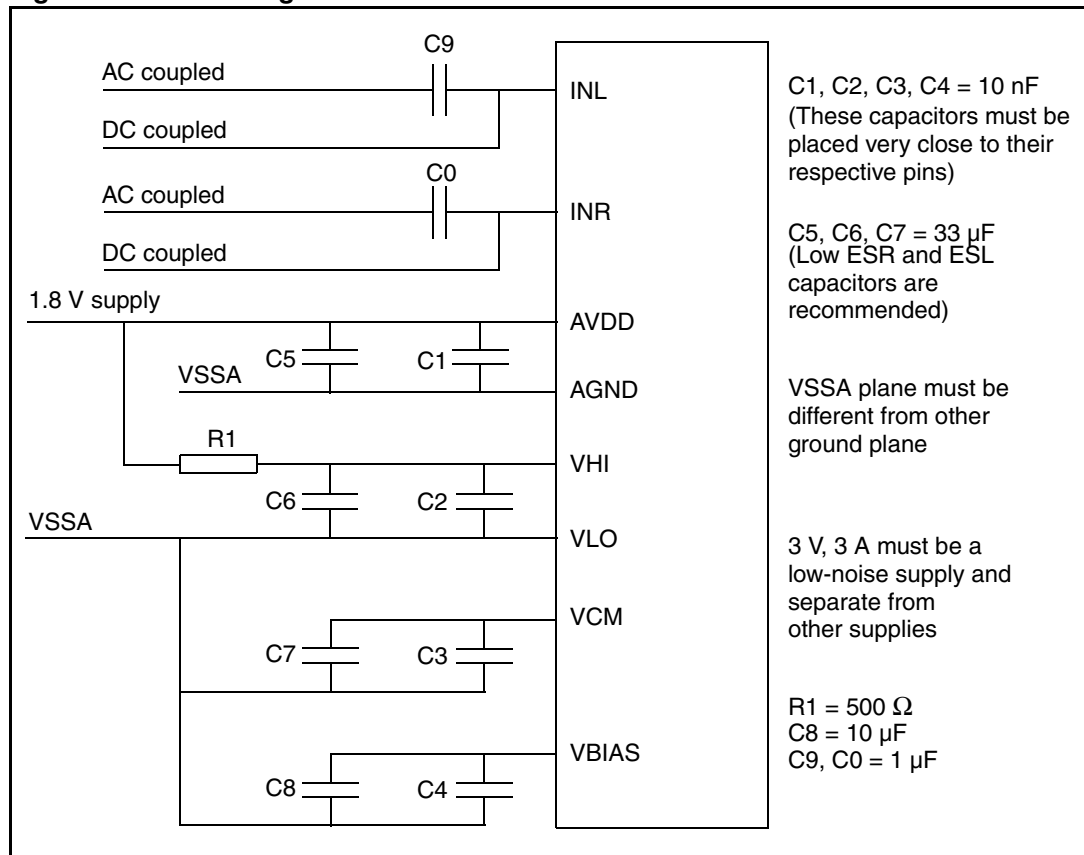

6.3 Configuration examples

The ADC sampling frequency can be selected from three values:

- normal (from 32 kHz to 48 kHz)
- low (from 16 kHz to 24 kHz)
- very-low (from 8 kHz to 12 kHz)

The setting is done through register bits MISC.ADC_FS_RANGE (see [MISC on page 50](#) for details). For all other settings, register ADCCFG is used (see [ADCCFG on page 49](#) for details).

7 Driver configuration

A driver configuration is available that allows PWM commands to be used on an external power device. For this purpose, the output serial audio interface is disabled and the respective pins have an alternative name and new functionality, as shown in [Table 15](#).

Table 15. Pin functionality in driver-configuration mode

Pin	Alternative pin name and functionality
BICKO	PWM1A (external bridge PWM command for output 1A)
LRCKO	PWM1B (external bridge PWM command for output 1B)
SDATAO	PWM2A (external bridge PWM command for output 2A)
CLKOUT	PWM2B (external bridge PWM command for output 2B)
POWERFAULT	EADP (external audio power-down signal)

The driver configuration is selected with two programmable registers PWMINT1 = 0x93 and PWMINT2 = 0x81 (see [PWMINT1 on page 51](#) and [PWMINT2 on page 51](#)).

7.1 I²S bypass

A configuration is available which allows the bypassing of the I²S input signal straight to the I²S output signal.

This configuration is set using two programmable registers PWMINT1 = 0x93 and PWMINT2 = 0x80 (see [PWMINT1 on page 51](#) and [PWMINT2 on page 51](#)).

8 Serial audio interface

This section includes information about the audio interface.

8.1 Specifications

The serial-to-parallel interface and the parallel-to-serial interface can have different sampling rates.

The following terms are used in this section:

- **BICKL active edge:** Pins SDATAI, SDATAO, LRCLKI, LRCLKO always change synchronously with BITCLK active edges. The active edge can be configured to a rising or falling edge via register programming.
- **BICKL strobe edge:** Pins SDATAI, SDATAO, LRCLKI, LRCLKO should be stable near BICKL strobe edges, the slave device is able to use strobe edges to latch serial data internally.

8.2 Master mode

In this mode, pins BICLK/BICLKO and pins LRCLK/LRCLKO are configured as outputs.

Figure 7. Master mode

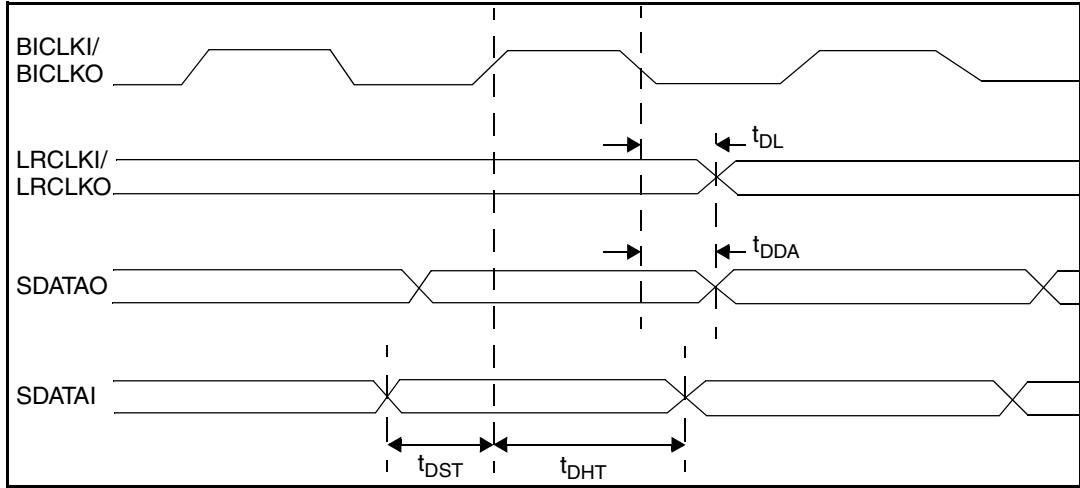

Table 16. Master mode

Parameter	Symbol	Min	Typ	Max	Unit
LRCLKI/LRCLKO propagation delay from BICLK active edge	t_{DL}	0		10	ns
SDATAI propagation delay from BICLK/O active edge	t_{DDA}	0		15	ns
Sdatao setup time to BICLK/O strobing edge	t_{DST}	10			ns
Sdatao hold time from BICLK/O strobing edge	t_{DHT}	10			ns

8.3 Slave mode

In this mode, pins BICKI/O and pins LRCLKI/O are configured as inputs.

Figure 8. Slave mode

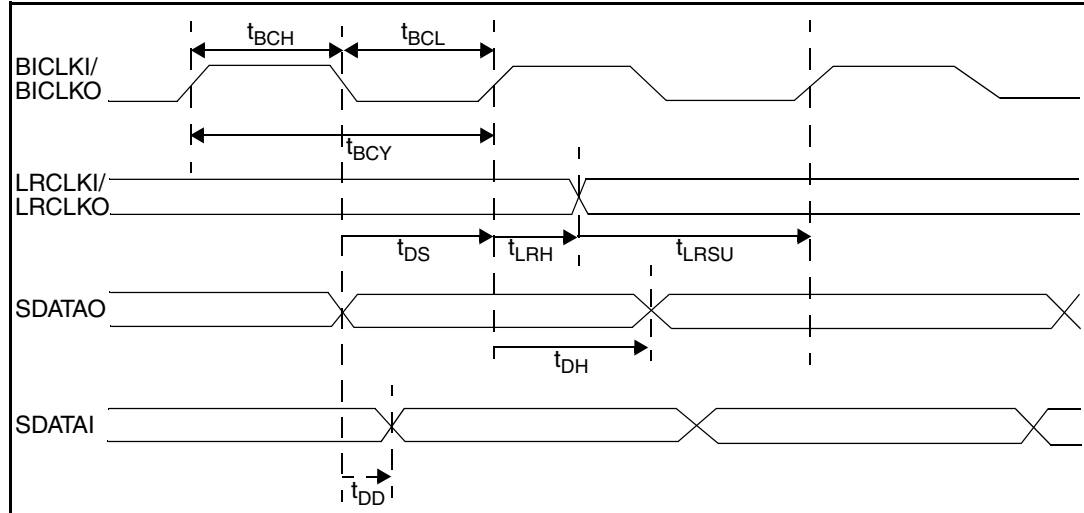

Table 17. Slave mode

Parameter	Symbol	Min	Typ	Max	Unit
BICK cycle time	t_{BCY}	50			ns
BICK pulse width high	t_{BCH}	20			ns
BICK pulse width low	t_{BCL}	20			ns
LRCLKI/LRCLKO setup time to BICK strobing edge	t_{LRSU}	10			ns
LRCLKI/LRCLKO hold time to BICK strobing edge	t_{LRH}	10			ns
SDATAO setup time to BICK strobing edge	t_{DS}	10			ns
SDATAO hold time to BICK strobing edge	t_{DH}	10			ns
SDATAI propagation delay from BICK active edge	t_{DD}	0		10	ns

8.4 Serial formats

Different audio formats are supported in both master and slave modes. Clock and data configurations can be customized to match most of the serial audio protocols available on the market.

Data length can be customized for 8-, 16-, 24-, and 32-bit.

Figure 9. Right justified

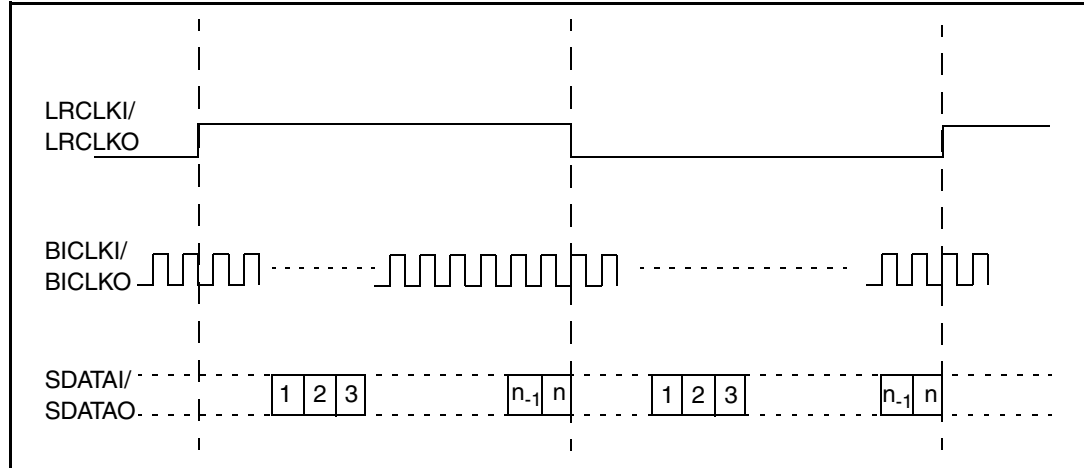
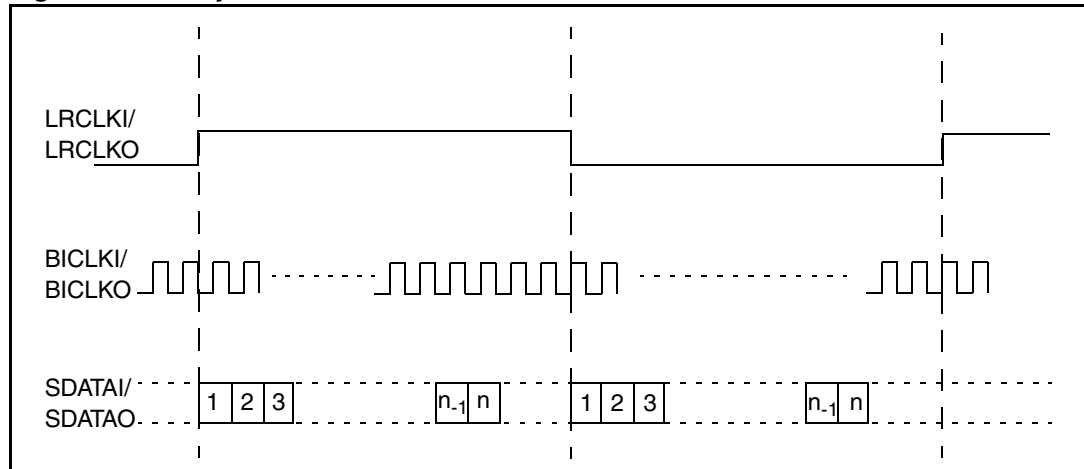
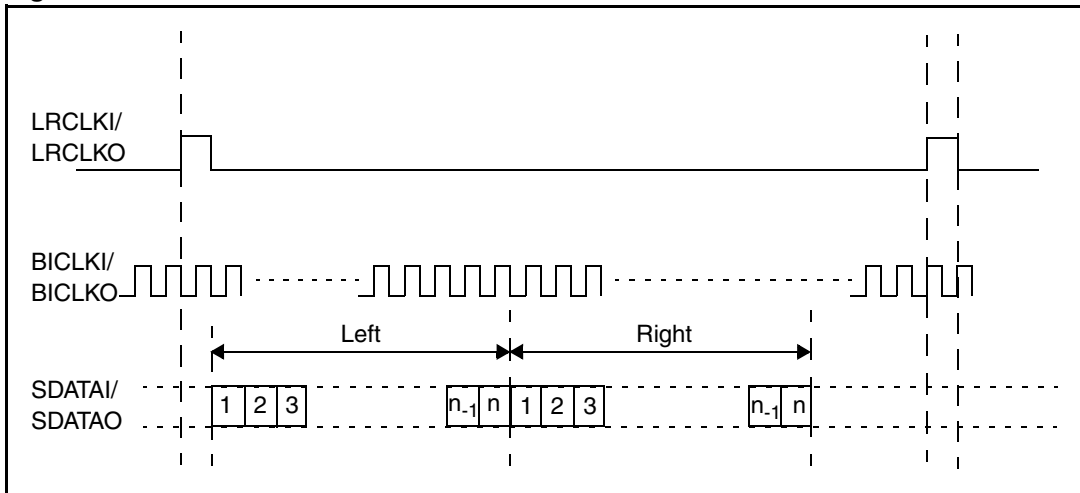

Figure 10. Left justified



8.4.1 DSP

Figure 11. DSP



8.4.2 I²S

Figure 12. I²S

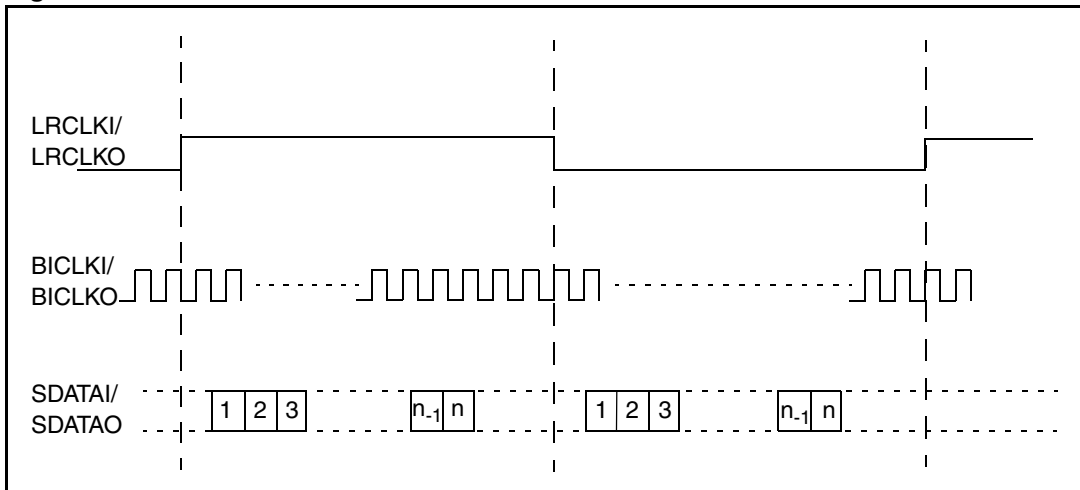

8.4.3 PCM/IF (non-delayed mode)

- MSB first
- 16-bit data

Figure 13. PCM/IF (non delayed mode)

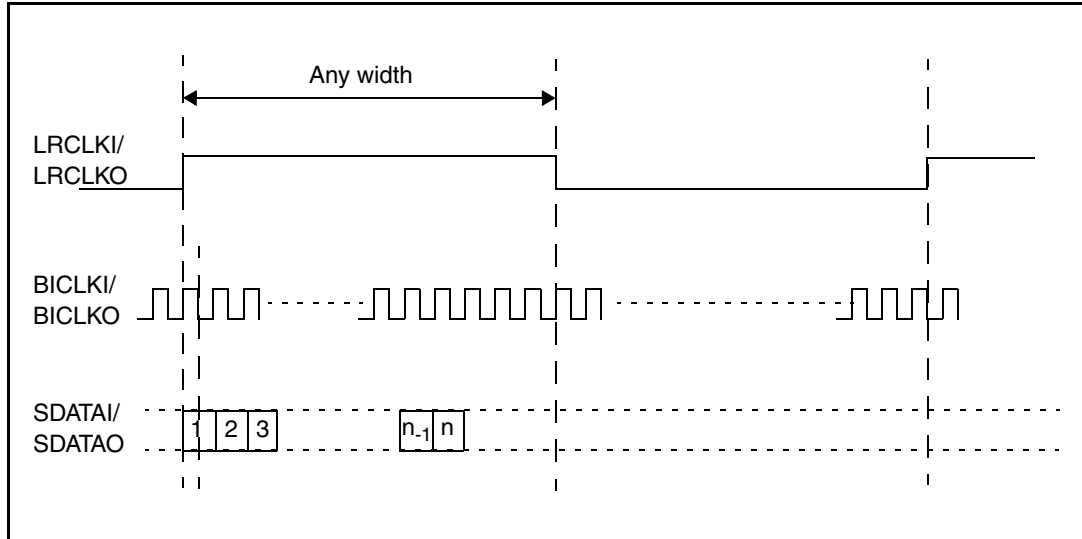

8.4.4 PCM/IF (delayed mode)

- MSB first
- 16-bit data

Figure 14. PCM/IF (delayed mode)

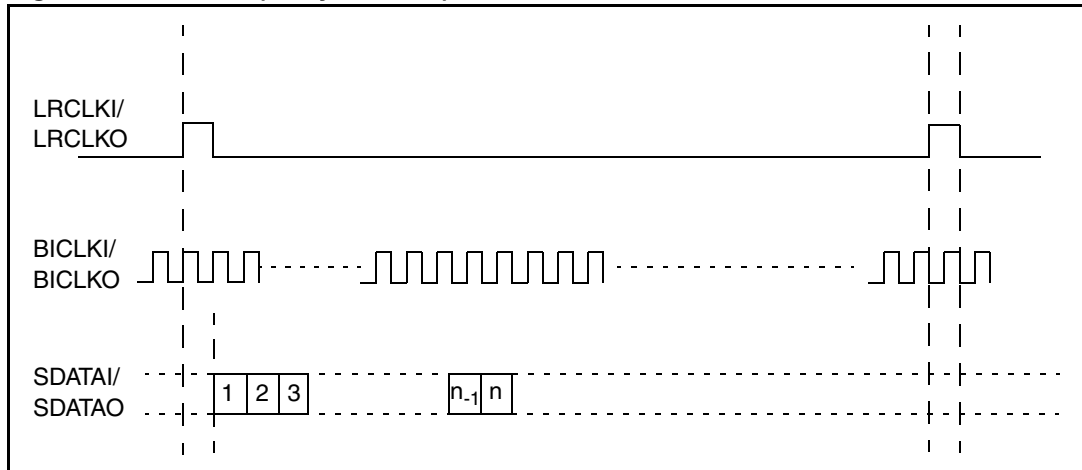

9 I²C interface

This section describes the communication protocol of the I²C interface.

9.1 Data transition and change

Data changes on the SDA line must only occur when the SCL clock is low. SDA transition while the clock is high is used to identify a start or stop condition.

9.2 Start condition

A start condition is identified by a high to low transition of the data bus SDA signal while the clock signal SCL is stable in the high state. A start condition must precede any command for data transfer.

9.3 Stop condition

A stop condition is identified by low to high transition of the data bus SDA signal while the clock signal SCL is stable in the high state. A stop condition terminates communication between the STA529 and the master bus.

9.4 Data input

During data input, the STA529 samples the SDA signal on the rising edge of clock SCL. For correct device operation the SDA signal must be stable during the rising edge of the clock and the data can change only when the SCL line is low.

9.5 Device addressing

To start communication between the master and the STA529, the master must initiate with a start condition. Following this, the master sends onto the SDA line 8 bits (MSB first) corresponding to the device select address and read or write mode.

The 7 most significant bits are the device address identifiers, corresponding to the I²C bus definition. In the STA529, the I²C interface has the device address 0x34.

The 8th bit (LSB) identifies read or write operation (R/W), this bit is set to 1 in read mode and 0 in write mode. After a start condition, the STA529 identifies on the bus the device address and if a match is found, it acknowledges the identification on SDA bus during the 9th bit time. The byte following the device identification byte is the internal space address.

9.6 Write operation

Following the start condition the master sends a device select code with the R/W bit set to 0. The STA529 acknowledges this and the writes to the byte of the internal address. After receiving the internal byte address, the STA529 responds with an acknowledgement.

9.6.1 Byte write

In the byte-write mode the master sends one data byte. This is acknowledged by the STA529. The master then terminates the transfer by generating a stop condition.

9.6.2 Multi-byte write

The multi-byte write modes can start from any internal address. The master generates a stop condition which terminates the transfer.

9.7 Read operation

9.7.1 Current address byte read

Following the start condition the master sends a device select code with the R/W bit set to 1. The STA529 acknowledges this and then responds by sending one byte of data. The master then terminates the transfer by generating a stop condition.

9.7.2 Current address multi-byte read

The multi-byte read modes can start from any internal address. Sequential data bytes are read from sequential addresses within the STA529. The master acknowledges each data byte read and then generates a stop condition terminating the transfer.

9.7.3 Random address byte read

Following the start condition the master sends a device select code with the R/W bit set to 0. The STA529 acknowledges this and then the master writes the internal address byte. After receiving the internal byte address, the STA529 again responds with an acknowledgement. The master then initiates another start condition and sends the device select code with the R/W bit set to 1. The STA529 acknowledges this and then responds by sending one byte of data. The master then terminates the transfer by generating a stop condition.

9.7.4 Random address multi-byte read

The multi-byte read modes could start from any internal address. Sequential data bytes are read from sequential addresses within the STA529. The master acknowledges each data byte read and then generates a stop condition terminating the transfer.

Figure 15. I²C write operations

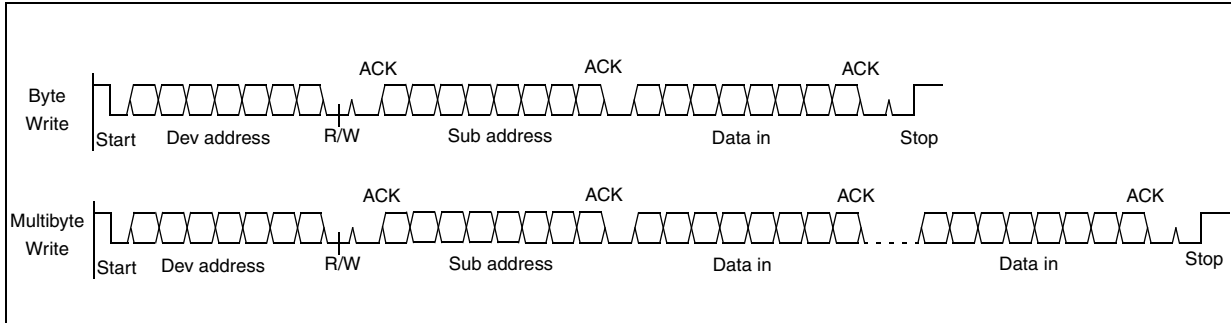
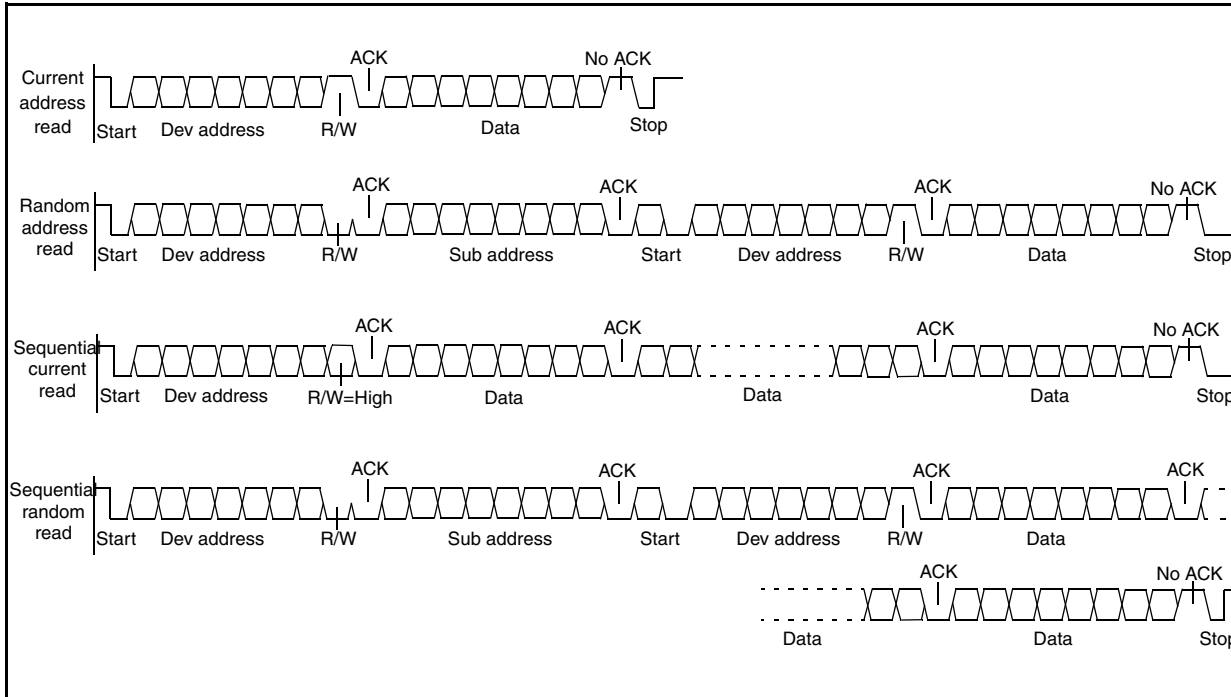

Figure 16. I²C read operations



10 Registers

This section includes register information.

10.1 Summary

Table 18. Register summary

Address	Name	Bit 7	Bit 6	Bit 5	Bit 4	Bit 3	Bit 2	Bit 1	Bit 0
0x00	FFXCFG0	MUTE	POW_STBY	SOFT_VOL_ON	BIN_SOFTS_TART	TIM_SOFT_VOL[3:0]			
0x01	FFXCFG1	L1_R2	MUTE_ON_INVALID	PWM_MODE[1:0]		PWM_SHIFT[1:0]			
0x02	MVOL	SET_VOL_MASTER[7:0]							
0x03	LVOL	SET_VOL_LEFT[7:0]							
0x04	RVOL	SET_VOL_RIGHT[7:0]							
0x05	TTF0	TIM_TS_FAULT[15:8]							
0x06	TTF1	TIM_TS_FAULT[7:0]							
0x07	TTP0	TIM_TS_POWUP[15:8]							
0x08	TTP1	TIM_TS_POWUP[7:0]							
0x0A	S2PCFG0	BICLK_STRB	LRCLK_LEFT	SHARE_BILR	MSB_FIRST	DATA_FORMAT[2:0]			MASTER_MODE
0x0B	S2PCFG1	PDATA_LENGTH[1:0]		BICLK_OS[1:0]		MAP_L[1:0]		MAP_R[1:0]	
0x0C	P2SCFG0	BICLK_STRB	LRCLK_LEFT	SDATAO_ACT	MSB_FIRST	DATA_FORMAT[2:0]			MASTER_MODE
0x0D	P2SCFG1	PDATA_LENGTH[1:0]		BICLK_OS[1:0]		MAP_L[1:0]		MAP_R[1:0]	
0x14	PLLCFG0	PLL_DIRECT_PROG	FRAC_CTRL	DITHER_DISABLE[1:0]		IDF[3:0]			
0x15	PLLCFG1	FRAC_INPUT[15:8]							
0x16	PLLCFG2	FRAC_INPUT[7:0]							
0x17	PLLCFG3	STRB	STRB_BYP_ASS	NDIV[5:0]					
0x18	PLLPE	PLL_BYP_UNL	BICLK2PLL	PLL_PWDN	PFE1A	PFE1B	PFE2A	PFE2B	RESET_FAULT
0x19	PLLST	PLL_UNLOCK	PLL_PWD_STATE	PLL_BYP_STATE					
0x1E	ADCCFG	PGA[2:0]			INSEL	STBY	BYPASS_CALIB	CLKENBL	
0x1F	CKOCFG	CLKOUT_DIS	CLKOUT_SEL[1:0]						
0x20	MISC	OSC_DIS	P2P_FS_RANGE[2:0]			ADC_FS_RANGE[1:0]		P2P_IN_ADC	CORE_CLKENBL
0x21	PADST0	Reserved							
0x22	PADST1	Reserved							
0x23	FFXST						INVALID_INP_FBK	MUTE_INT_FBK	BINSS_FBK
0x28	BISTRUN	Reserved							

Table 18. Register summary (continued)

Address	Name	Bit 7	Bit 6	Bit 5	Bit 4	Bit 3	Bit 2	Bit 1	Bit 0
0x29	BISTST0	Reserved							
0x2A	BISTST1	Reserved							
0x2B	BISTST2	Reserved							
0x2D	PWMINT1	PWM_INT[15:8]							
0x2E	PWMINT2	PWM_INT[7:0]							
0x32	POWST	POWER DOWN	POW_TRISTATE	POW_FAULT1A	POW_FAULT1B	POW_FAULT2A	POW_FAULT2B		

10.2 General registers

FFXCFG0

FFX configuration register 0

Bit 7	Bit 6	Bit 5	Bit 4	Bit 3	Bit 2	Bit 1	Bit 0
MUTE	POW_STBY	SOFT_VOL_ON	BIN_SOFTSTART	TIM_SOFT_VOL[3:0]			

Address: 0x00

Type: R/W

Buffer: No

Reset: 0x75

Description:

- 7 MUTE:
 - 0: default
 - 1: FFX output is zero
- 6 POW_STBY:
 - 0: FFX bridge is in power-up mode
 - 1: FFX bridge is put in standby mode (default)
- 5 SOFT_VOL_ON:
 - 0: smooth transition not active
 - 1: smooth transition when changing volume control (default)
- 4 BIN_SOFTSTART:
 - Reserved (1: default)
- 3:0 TIM_SOFT_VOL: volume control time step for any 0.5 dB volume change
 - Time is $(2^{TIM_SOFT_VOL}) * 20.83 \mu s$
 - Default is 666.66 μs

FFXCFG1 Configuration register 1

Bit 7	Bit 6	Bit 5	Bit 4	Bit 3	Bit 2	Bit 1	Bit 0
L1_R2	MUTE_ON_INVALID	PWM_MODE[1:0]		PWM_SHIFT[1:0]			

Address: 0x01

Type: R/W

Buffer: No

Reset: 0xf8

Description:

- 7 L1_R2: channel mapping:
 - 0: right channel is mapped to output channel 1 and left channel is mapped to output channel 2
 - 1: left channel is mapped to output channel 1 and right channel is mapped to output channel 2 (default)
- 6 MUTE_ON_INVALID: mutes PWM outputs if invalid digital data is received:
 - 0: outputs are not muted
 - 1: outputs are muted (default)
- 5:4 PWM_MODE[1:0]:
 - 00: binary (output B is opposite of output A)
 - 01: binary headphones (output B is 50 % duty cycle)
 - 10: ternary
 - 11: phase shift (default)
- 3:2 PWM_SHIFT[1:0]:
 - 10: default
 - PWM period-shift between channels 1 and 2
 - Value is $N * 90^\circ$
 - Default is 180°
- 1:0 Reserved (00: default)

MVOL Master volume control register

Bit 7	Bit 6	Bit 5	Bit 4	Bit 3	Bit 2	Bit 1	Bit 0
SET_VOL_MASTER[7:0]							

Address: 0x02

Type: R/W

Buffer: No

Reset: 0x00

Description:

- 7:0 SET_VOL_MASTER[7:0]: master volume control:
 - From 0 dB to -127.5 dB in 0.5 dB steps

LVOL **Left channel volume control register**

Bit 7	Bit 6	Bit 5	Bit 4	Bit 3	Bit 2	Bit 1	Bit 0
SET_VOL_LEFT[7:0]							

Address: 0x03

Type: R/W

Buffer: No

Reset: 0x48

Description:

7:0 SET_VOL_LEFT[7:0]: left channel volume control:
 0100 1000: default
 Left channel volume control (from +36 dB to -91.5 dB in 0.5 dB steps)
 Default value corresponds to 0 dB

RVOL **Right channel volume control register**

Bit 7	Bit 6	Bit 5	Bit 4	Bit 3	Bit 2	Bit 1	Bit 0
SET_VOL_RIGHT[7:0]							

Address: 0x04

Type: R/W

Buffer: No

Reset: 0x48

Description:

7:0 SET_VOL_RIGHT[7:0]: right channel volume control:
 0100 1000: default
 Right channel volume control (from +36 dB to -91.5 dB in 0.5 dB steps)
 Default value corresponds to 0 dB

TTF0**Tri-state time-after-fault register 0**

Bit 7	Bit 6	Bit 5	Bit 4	Bit 3	Bit 2	Bit 1	Bit 0
TIM_TS_FAULT[15:8]							

Address: 0x05**Type:** R/W**Buffer:** No**Reset:** 0x00**Description:**

7:0 MSBs of TIM_TS_FAULT[15:8]:

See [TTF1 on page 39](#).**TTF1****Tri-state time-after-fault register 1**

Bit 7	Bit 6	Bit 5	Bit 4	Bit 3	Bit 2	Bit 1	Bit 0
TIM_TS_FAULT(7:0)							

Address: 0x06**Type:** R/W**Buffer:** No**Reset:** 0x02**Description:**

7:0 LSBs of TIM_TS_FAULT[7:0]: time in which power is held in tri-state mode after a fault signal:

Time is TIM_TS_FAULT * 83.33 μ s.Default value corresponds to 166.66 μ s tri-state time after fault

TTP0 Tri-state time-after-power-up register 0

Bit 7	Bit 6	Bit 5	Bit 4	Bit 3	Bit 2	Bit 1	Bit 0
TIM_TS_POWUP[15:8]							

Address: 0x07

Type: R/W

Buffer: No

Reset: 0x00

Description:

7:0 MSBs of TIM_TS_POWUP[15:8]:
See register [TTP1](#).

TTP1 Tri-state time-after-power-up register 1

Bit 7	Bit 6	Bit 5	Bit 4	Bit 3	Bit 2	Bit 1	Bit 0
TIM_TS_POWUP[7:0]							

Address: 0x08

Type: R/W

Buffer: No

Reset: 0x02

Description:

7:0 LSBs of TIM_TS_POWUP[7:0]: time in which power is held in tri-state mode after a power-up signal:
Time is $TIM_TS_POWUP * 83.33 \mu s$
Default value corresponds to 166.66 μs tri-state time after power-up

S2PCFG0

Serial-to-parallel audio interface configuration register 0

Bit 7	Bit 6	Bit 5	Bit 4	Bit 3	Bit 2	Bit 1	Bit 0
BICKL_STRB	LRCLK_LEFT	SHARE_BILR	MSB_FIRST	DATA_FORMAT[2:0]			MASTER_MODE

Address: 0x0A

Type: R/W

Buffer: No

Reset: 0xD2

Description:

- 7 BICKL_STRB:
 - 0: bit clock strobe edge is falling edge, bit clock active edge is rising edge
 - 1: bit clock strobe edge is rising edge, bit clock active edge is falling edge (default)
- 6 LRCLK_LEFT:
 - 0: left/right clock is low for left channel, high for right channel
 - 1: left/right clock is high for left channel, low for right channel (default)
- 5 SHARE_BILR:
 - 0: default
 - 1: left/right clock and bit clock are shared between serial-parallel interface and parallel-to-serial interface, BICKLI and LRCLKI are used
- 4 MSB_FIRST:
 - 0: LSB first
 - 1: MSB first (default)
- 3:1 DATA_FORMAT[2:0]: serial interface protocol format:
 - 000: left Justified
 - 001: I²S (default)
 - 010: right justified
 - 100: PCM no delay
 - 101: PCM delay
 - 111: DSP
 - 001: default
- 0 MASTER_MODE:
 - 0: default
 - 1: serial interface is in master mode

S2PCFG1

Serial-to-parallel audio interface configuration register 1

Bit 7	Bit 6	Bit 5	Bit 4	Bit 3	Bit 2	Bit 1	Bit 0
PDATA_LENGTH[1:0]		BICKL_OS[1:0]		MAP_L[1:0]		MAP_R[1:0]	

Address: 0x0B

Type: R/W

Buffer: No

Reset: 0x91

Description:

- 7:6 PDATA_LENGTH[1:0]: serial-to-parallel interface data length:
 10: default
 Length is (N+1) * 8 bit
 Default is 24 bit
- 5:4 BICKL_OS[1:0]: bit clock oversampling:
 01: default
 Value is (N+1) * 32 fs (where fs = sampling frequency)
 Default is 64 fs
- 3:2 MAP_L[1:0]: left data-mapping slot:
 00: default
 Value is nth slot
 Default is slot0
- 1:0 MAP_R[1:0]: right data-mapping slot:
 01: default
 Value is nth slot
 Default is slot

P2SCFG0

Parallel-to-serial audio interface configuration register 0

Bit 7	Bit 6	Bit 5	Bit 4	Bit 3	Bit 2	Bit 1	Bit 0
BICKLK_STRB	LRCLK_LEFT	SDATAO_ACT	MSB_FIRST	DATA_FORMAT[2:0]			MASTER_MODE

Address: 0x0C

Type: R/W

Buffer: No

Reset: 0xD3

Description:

- 7 BICKLK_STRB: defines the bit clock edges:
 - 0: strobe is falling edge, active edge is rising
 - 1: strobe is rising edge, active edge is falling (default)
- 6 LRCLK_LEFT: defines the channel for the LR clock:
 - 0: clock is low for left channel, high for right channel
 - 1: clock is high for left channel, low for right channel (default)
- 5 SDATAO_ACT: sets the behavior of pin SDATAO:
 - 0: output is tri-stated when no data is sent (default)
 - 1: output is never in tri-state (it is 0 when no data is sent)
- 4 MSB_FIRST: data alignment in the protocol for SDATAI and SDATAO:
 - 0: LSB is the first bit
 - 1: MSB is the first bit (default)
- 3:1 DATA_FORMAT[2:0]: serial interface protocol format:
 - 000: left justified
 - 001: I²S (default)
 - 010: right justified
 - 100: PCM no delay
 - 101: PCM delay
 - 111: DSP
- 0 MASTER_MODE: selects serial interface master/slave mode:
 - 0: slave
 - 1: master (default)

P2SCFG1**Parallel-to-serial audio interface configuration register 1**

Bit 7	Bit 6	Bit 5	Bit 4	Bit 3	Bit 2	Bit 1	Bit 0
PDATA_LENGTH[1:0]		BICKL_OS[1:0]		MAP_L[1:0]		MAP_R[1:0]	

Address: 0x0D**Type:** R/W**Buffer:** No**Reset:** 0x91**Description:**

- 7:6 PDATA_LENGTH[1:0]: serial-to-parallel interface data length:
10: default
Length is (PDATA_LENGTH+1) * 8 bit
Default is 24 bits
- 5:4 BICKL_OS[1:0]: bit clock oversampling:
01: default
Value is (BICKL_OS+1) * 32 fs
Default is 64 fs
- 3:2 MAP_L[1:0]: left data-mapping slot:
00: default
Value is nth slot
Default is slot0
- 1:0 MAP_R[1:0]: right channel data-mapping slot:
01: default
Value is nth slot
Default is slot1

PLLCFG0 PLL configuration register 0

Bit 7	Bit 6	Bit 5	Bit 4	Bit 3	Bit 2	Bit 1	Bit 0
PLL_DIRECT_PROG	FRAC_CTRL	DITHER_DISABLE[1:0]		IDF[3:0]			

Address: 0x14

Type: R/W

Buffer: No

Reset: 0x00

Description:

- 7 PLL_DIRECT_PROG: PLL programming:
 - 0: default
 - 1: PLL is programmed according to the PLLCFG register settings
- 6 FRAC_CTRL:
 - 0: default
 - 1: PLL fractional-frequency synthesis is enabled
- 5:4 DITHER_DISABLE[1:0]:
 - 00: default
 - MSB = 1: disables rectangular PDF dither input to SDM
 - LSB = 1: disables triangular PDF dither input to SDM
- 3:0 IDF[3:0]: PLL input division factor:
 - 0000: IDF = 1 (default)
 - 0001: IDF = 1
 - 0010: IDF = 2
 - ...
 - 1111: IDF = 15

PLLCFG1 PLL configuration register 1

Bit 7	Bit 6	Bit 5	Bit 4	Bit 3	Bit 2	Bit 1	Bit 0
FRAC_INPUT[15:8]							

Address: 0x15

Type: R/W

Buffer: No

Reset: 0x00

Description:

- 7:0 FRAC_INPUT[15:8]: 16 bits are used to set the fractional part of PLL multiplication factor:
 - 0000 0000: default

PLLCFG2 **PLL configuration register 2**

Bit 7	Bit 6	Bit 5	Bit 4	Bit 3	Bit 2	Bit 1	Bit 0
FRAC_INPUT[7:0]							

Address: 0x16

Type: R/W

Buffer: No

Reset: 0x00

Description:

7:0 FRAC_INPUT[7:0]: 16 bits are used to set the fractional part of PLL multiplication factor:
0000 0000: default

PLLCFG3 **PLL configuration register 3**

Bit 7	Bit 6	Bit 5	Bit 4	Bit 3	Bit 2	Bit 1	Bit 0
STRB	STRB_BYPASS	NDIV[5:0]					

Address: 0x17

Type: R/W

Buffer: No

Reset: 0x00

Description:

- 7 STRB: asynchronous strobe input to the fractional controller:
0: default
- 6 STRB_BYPASS: standby bypass:
0: STRB signal is not bypassed (default)
1: STRB signal is bypassed
- 5:0 NDIV[5:0]: PLL multiplication factor (integral part) named as loop division factor:
0000 XX: LDF = NA
0001 00: LDF = NA
0001 01: LDF = 5
...
1101 11: LDF = 55
111X XX: LDF = NA
0000 00: default

PLL/PFE PLL/POP-free configuration register

Bit 7	Bit 6	Bit 5	Bit 4	Bit 3	Bit 2	Bit 1	Bit 0
PLL_BYP_UNL	BICLK2PLL	PLL_PWDN	PFE1A	PFE1B	PFE2A	PFE2B	RESET_FAULT

Address: 0x18

Type: R/W

Buffer: No

Reset: 0x00

Description:

- 7 PLL_BYP_UNL: PLL bypass:
 - 0: PLL is not bypassed (default)
 - 1: PLL is bypassed when not locked
- 6 BICLK2PLL:
 - 0: default
 - 1: BICLK1 is input to PLL
- 5 PLL_PWDN:
 - 0: default
 - 1: PLL is put in power-down mode
- 4 PFE1A:
 - 0: default
 - 1: POP-free resistances are connected to output 1A
- 3 PFE1B:
 - 0: default
 - 1: POP-free resistances are connected to output 1B
- 2 PFE2A:
 - 0: default
 - 1: POP-free resistances are connected to output 2A
- 1 PFE2B:
 - 0: default
 - 1: POP-free resistances are connected to output 2B
- 0 RESET_FAULT:
 - 0: default
 - 1: fault signal in the i2c register POWST is reset

PLLST **PLL status register (RO)**

Bit 7	Bit 6	Bit 5	Bit 4	Bit 3	Bit 2	Bit 1	Bit 0
PLL_UNLOCK	PLL_PWD_STATE	PLL_BYP_STATE					

Address: 0x19

Type: RO

Buffer: No

Reset: Undefined

Description:

- 7 PLL_UNLOCK: PLL unlock state:
 - 0: PLL is not in unlock state
 - 1: PLL is in unlock state
- 6 PLL_PWD_STATE: PLL power-down state:
 - 0: PLL is not in power-down state
 - 1: PLL is in power-down state
- 5 PLL_BYP_STATE: PLL bypass state:
 - 0: PLL is not in bypass state
 - 1: PLL is in bypass state
- 4:0 Reserved

ADCCFG **ADC configuration register**

Bit 7	Bit 6	Bit 5	Bit 4	Bit 3	Bit 2	Bit 1	Bit 0
	PGA[2:0]		INSEL	STBY	BYPASS_CALIB	CLKENBL	

Address: 0x1E
Type: RO
Buffer: No
Reset: Undefined

Description:

- 7:5 PGA[2:0]: gain selection bits for the ADC programmable gain amplifier:
 000: default
 Values are from 0 to 42 dB in 6 dB steps
- 4 INSEL:
 0: line input selected (default)
 1: microphone input selected (it must be applied to INL line)
- 3 STBY: ADC standby mode:
 0: ADC in power-up mode (default)
 1: ADC in standby mode
- 2 BYPASS_CALIB:
 0: ADC DC-removal block not bypassed (default)
 1: ADC DC-removal block bypassed
- 1 CLKENBL: Clock enable:
 0: system clock not enabled
 1: system clock available at ADC input (default)
- 0 Reserved

CKOCFG **Clock-out configuration register**

Bit 7	Bit 6	Bit 5	Bit 4	Bit 3	Bit 2	Bit 1	Bit 0
CLKOUT_DIS	CLKOUT_SEL[1:0]						

Address: 0x1F
Type: R/W
Buffer: No
Reset: Undefined

Description:

- 7 CLKOUT_DIS: CLKOUT PAD disabled
 0: default
 1: enabled
- 6:5 CLKOUT_SEL[1:0]:
 00: default
 The CLKOUT output frequency is the PLL output frequency divided by 2^{CLKOUT_SEL} .
- 4:0 Reserved

MISC **Miscellaneous configuration register**

Bit 7	Bit 6	Bit 5	Bit 4	Bit 3	Bit 2	Bit 1	Bit 0
OSC_DIS	P2P_FS_RANGE[2:0]			ADC_FS_RANGE[1:0]		P2P_IN_ADC	CORE_CLKENBL

Address: 0x20

Type: R/W

Buffer: No

Reset: 0x21

Description:

- 7 OSC_DIS: enable/disable crystal oscillator:
 - 0: default
 - 1: disabled
- 6:4 P2P_FS_RANGE[2:0]: FFX audio frequency range:
 - 000: very low (fs = 8 to 12 kHz) (default)
 - 001: low (fs = 16 to 24 kHz) (default)
 - 010: normal (fs = 32 to 48 kHz)
 - 011: high (fs = 64 to 96 kHz)
 - 1X: very high (fs = 128 to 192 kHz)
- 3:2 ADC_FS_RANGE[2:0]: ADC audio frequency range:
 - 00: normal (fs = 32 to 48 kHz)
 - 00: low (fs = 16 to 24 kHz)
 - 1X: very low (fs = 8 to 12 kHz)
 - 00: default
- 1 P2P_IN_ADC: FFX input:
 - 0: FFX input is from serial-to-parallel audio interface (default)
 - 1: FFX input is from ADC
- 0 CORE_CLKENBL: availability of system clock:
 - 0: FFX system clock disabled
 - 1: FFX system clock enabled (default)

FFXST **FFX status register**

Bit 7	Bit 6	Bit 5	Bit 4	Bit 3	Bit 2	Bit 1	Bit 0
					INVALID_INP_FBK	MUTE_INT_FBK	

Address: 0x23
Type: RO
Buffer: No
Reset: Undefined

Description:
 7:3 Reserved
 2 INVALID_INP_FBK: invalid input status:
 1: invalid input sent to FFX
 1 MUTE_INT_FBK: FFX mute status
 1: FFX is in mute state
 0 Reserved

PWMINT1 **PWM driver configuration register 1**

Bit 7	Bit 6	Bit 5	Bit 4	Bit 3	Bit 2	Bit 1	Bit 0
PWM_INT1[7:0]							

Address: 0x2D
Type: R/W
Buffer: No
Reset: 0x00

Description:
 7:0 PWM_INT1[7:0]: see [Section 7: Driver configuration on page 25](#):
 0000 0000: default

PWMINT2 **PWM driver configuration register 2**

Bit 7	Bit 6	Bit 5	Bit 4	Bit 3	Bit 2	Bit 1	Bit 0
PWM_INT1[7:0]							

Address: 0x2E
Type: R/W
Buffer: No
Reset: 0x00

Description:
 7:0 PWM_INT1[7:0]: see [Section 7: Driver configuration on page 25](#):
 0000 0000: default

POWST Power bridge status register

Bit 7	Bit 6	Bit 5	Bit 4	Bit 3	Bit 2	Bit 1	Bit 0
POW_POWERDOWN	POW_TRISTATE	POW_FAULT1A	POW_FAULT1B	POW_FAULT2A	POW_FAULT2B		

Address: 0x32

Type: RO

Buffer: No

Reset: Undefined

Description:

- 7 POW_POWERDOWN: power-down bridge:
 - 0: not in power-down state
 - 1: power-down state
- 6 POW_TRISTATE:
 - 1: power bridge is in tri-state
- 5 POW_FAULT1A:
 - 1: power bridge 1A is in fault state
- 4 POW_FAULT1B:
 - 1: power bridge 1B is in fault state
- 3 POW_FAULT2A:
 - 1: power bridge 2A is in fault state
- 2 POW_FAULT2B:
 - 1: power bridge 2B is in fault state
- 1:0 Reserved

11 Package information

This section includes packaging information for the following packages:

- TFBGA48
- VFQFPN52

In order to meet environmental requirements, ST offers these devices in ECOPACK® packages. These package have a lead-free second level interconnect. The category of second level interconnect is marked on the package and on the inner box label, in compliance with JEDEC Standard JESD97. The maximum ratings related to soldering conditions are also marked on the inner box label. ECOPACK is an ST trademark. ECOPACK specifications are available at: www.st.com.

11.1 Package TFBGA48

Figure 17. Mechanical data (TFBGA48)

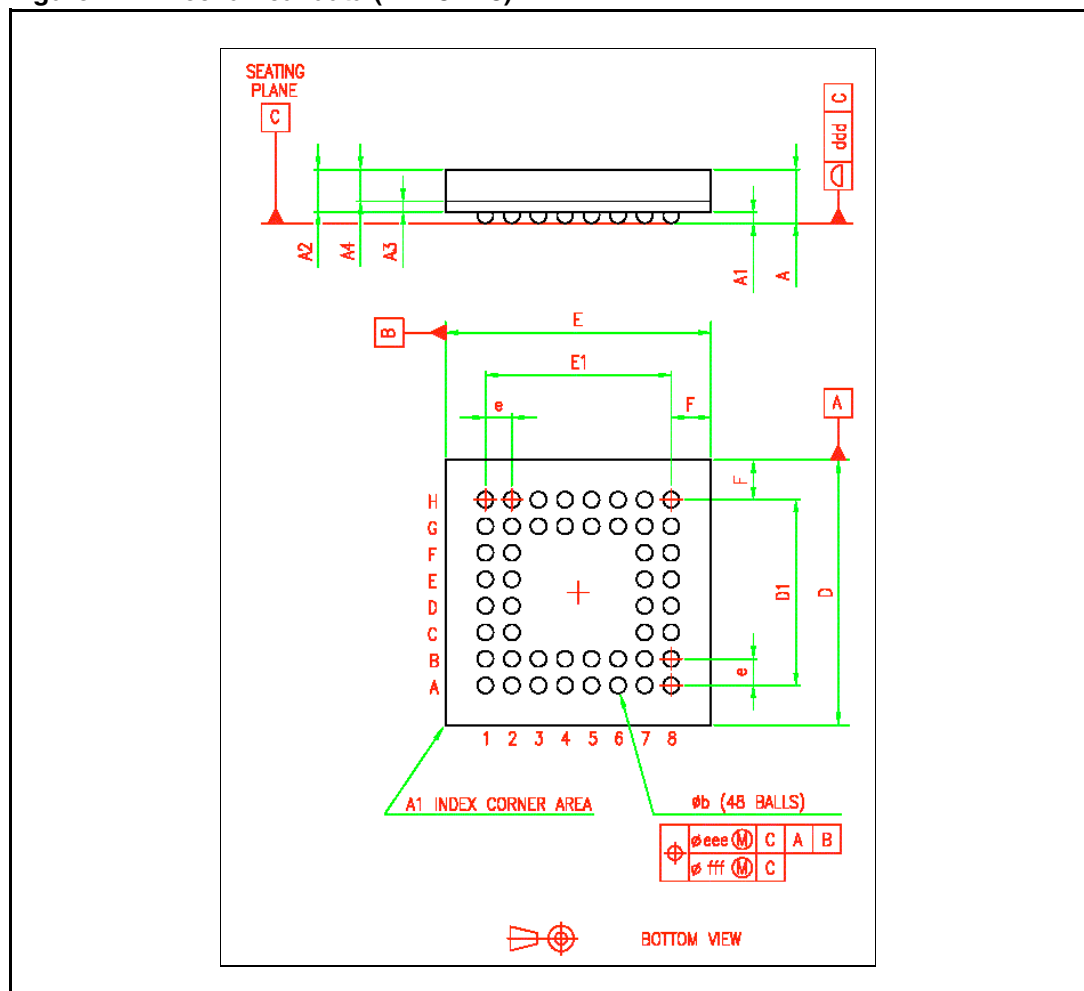

Table 19 gives the package dimensions.

Table 19. Package dimensions (TFBGA48)

Reference	Databook mm		
	Min	Typical	Max
A			1.20
A1	0.15		
A2		0.785	
A3		0.20	
A4			0.60
b	0.25	0.30	0.35
D	4.85	5.00	5.15
D1		3.50	
E	4.85	5.00	5.15
E1		3.50	
e		0.50	
F		0.75	
ddd			0.08
eee			0.15
fff			0.05

11.2 Package VFQFPN52

Figure 18. Mechanical data (VFQFPN52)

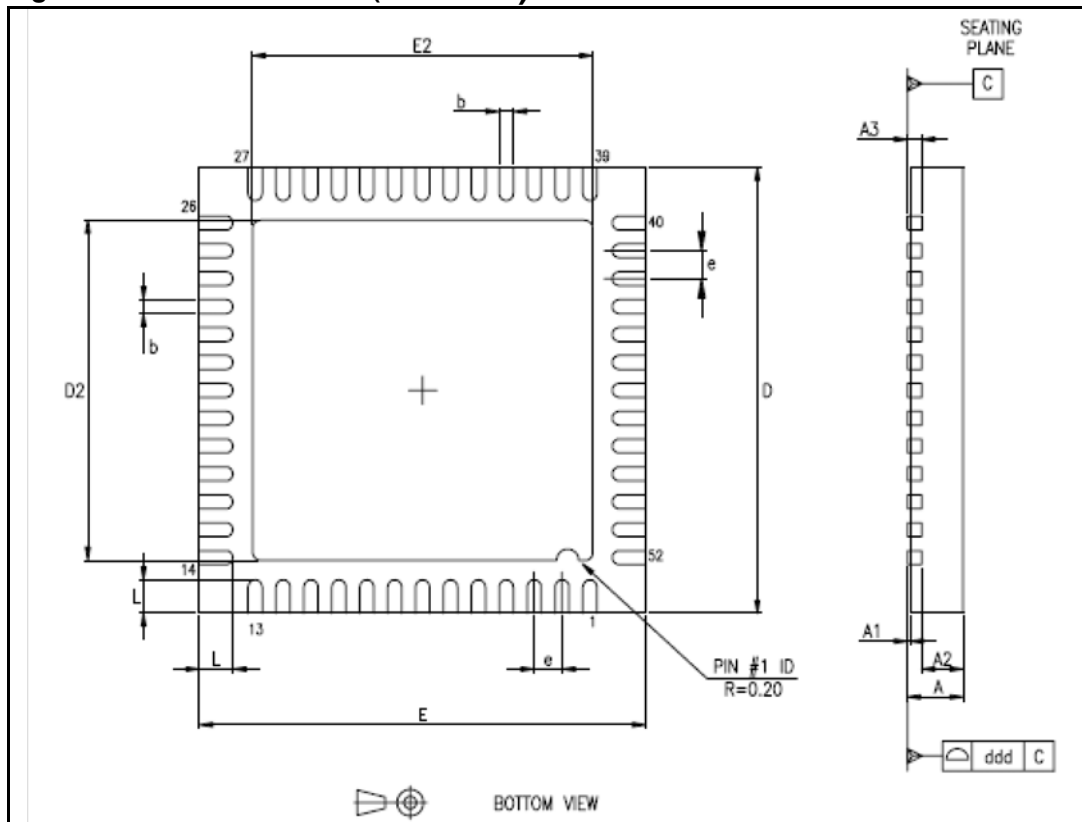

Table 20 gives the package dimensions.

Table 20. Package dimensions (VFQFPN52)

Reference	Databook mm		
	Min	Typical	Max
A	0.800	0.900	1.000
A1		0.020	0.050
A2		0.650	1.000
A3		0.250	
b	0.180	0.230	0.300
D	7.875	8.000	8.125
D2	2.750	5.700	6.250
E	7.875	8.000	8.125
E2	2.750	5.700	6.250
e	0.450	0.500	0.550
L	0.350	0.550	0.750
ddd			0.080

12 Revision history

Table 21. Document revision history

Date	Revision	Changes
10-Jan-2007	1	Initial release

Please Read Carefully:

Information in this document is provided solely in connection with ST products. STMicroelectronics NV and its subsidiaries ("ST") reserve the right to make changes, corrections, modifications or improvements, to this document, and the products and services described herein at any time, without notice.

All ST products are sold pursuant to ST's terms and conditions of sale.

Purchasers are solely responsible for the choice, selection and use of the ST products and services described herein, and ST assumes no liability whatsoever relating to the choice, selection or use of the ST products and services described herein.

No license, express or implied, by estoppel or otherwise, to any intellectual property rights is granted under this document. If any part of this document refers to any third party products or services it shall not be deemed a license grant by ST for the use of such third party products or services, or any intellectual property contained therein or considered as a warranty covering the use in any manner whatsoever of such third party products or services or any intellectual property contained therein.

UNLESS OTHERWISE SET FORTH IN ST'S TERMS AND CONDITIONS OF SALE ST DISCLAIMS ANY EXPRESS OR IMPLIED WARRANTY WITH RESPECT TO THE USE AND/OR SALE OF ST PRODUCTS INCLUDING WITHOUT LIMITATION IMPLIED WARRANTIES OF MERCHANTABILITY, FITNESS FOR A PARTICULAR PURPOSE (AND THEIR EQUIVALENTS UNDER THE LAWS OF ANY JURISDICTION), OR INFRINGEMENT OF ANY PATENT, COPYRIGHT OR OTHER INTELLECTUAL PROPERTY RIGHT.

UNLESS EXPRESSLY APPROVED IN WRITING BY AN AUTHORIZED ST REPRESENTATIVE, ST PRODUCTS ARE NOT RECOMMENDED, AUTHORIZED OR WARRANTED FOR USE IN MILITARY, AIR CRAFT, SPACE, LIFE SAVING, OR LIFE SUSTAINING APPLICATIONS, NOR IN PRODUCTS OR SYSTEMS WHERE FAILURE OR MALFUNCTION MAY RESULT IN PERSONAL INJURY, DEATH, OR SEVERE PROPERTY OR ENVIRONMENTAL DAMAGE. ST PRODUCTS WHICH ARE NOT SPECIFIED AS "AUTOMOTIVE GRADE" MAY ONLY BE USED IN AUTOMOTIVE APPLICATIONS AT USER'S OWN RISK.

Resale of ST products with provisions different from the statements and/or technical features set forth in this document shall immediately void any warranty granted by ST for the ST product or service described herein and shall not create or extend in any manner whatsoever, any liability of ST.

ST and the ST logo are trademarks or registered trademarks of ST in various countries.

Information in this document supersedes and replaces all information previously supplied.

The ST logo is a registered trademark of STMicroelectronics. All other names are the property of their respective owners.

© 2007 STMicroelectronics - All rights reserved

STMicroelectronics group of companies

Australia - Belgium - Brazil - Canada - China - Czech Republic - Finland - France - Germany - Hong Kong - India - Israel - Italy - Japan - Malaysia - Malta - Morocco - Singapore - Spain - Sweden - Switzerland - United Kingdom - United States of America

www.st.com