



# STK403-440

## Six-Channel Class AB Audio Power Amplifier IC 25 W × 6 Channels

### Preliminary

### Overview

The STK403-400 series products are audio power amplifier hybrid ICs that consist of optimally-designed discrete component power amplifier circuits that have been miniaturized using SANYO's unique insulated metal substrate technology (IMST). The adoption of a newly-developed low thermal resistance substrate allows this product to integrate six power amplifier channels in a single compact package. The adoption of a standby circuit in this device allows it to reduce impulse noise significantly as compared to earlier Sanyo products, in particular, the STK402-\*00 series products.

### Features

- Series of pin compatible power amplifiers ranging from 30 W/ch to 45 W/ch (10%/1 kHz) devices. The same printed circuit board can be used depending on the output power grade.
- Miniature packages
  - 78.0 mm × 32.0 mm × 9.0 mm \*
  - \*: Not including the pins.
- Output load impedance:  $R_L = 6 \Omega$
- Allowable load shorted time: 0.3 seconds
- Supports the use of standby and muting circuits.

### Package Dimensions

unit: mm

#### 4202-SIP28

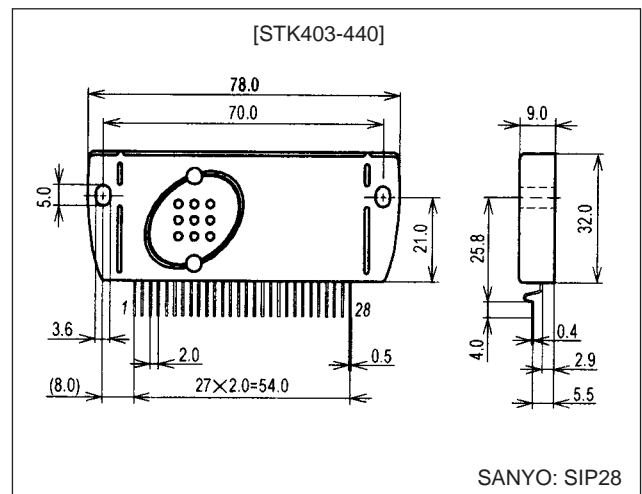

■ Any and all SANYO products described or contained herein do not have specifications that can handle applications that require extremely high levels of reliability, such as life-support systems, aircraft's control systems, or other applications whose failure can be reasonably expected to result in serious physical and/or material damage. Consult with your SANYO representative nearest you before using any SANYO products described or contained herein in such applications.

■ SANYO assumes no responsibility for equipment failures that result from using products at values that exceed, even momentarily, rated values (such as maximum ratings, operating condition ranges, or other parameters) listed in products specifications of any and all SANYO products described or contained herein.

**SANYO Electric Co., Ltd. Semiconductor Company**

TOKYO OFFICE Tokyo Bldg., 1-10, 1 Chome, Ueno, Taito-ku, TOKYO, 110-8534 JAPAN

## STK403-440

### Series Organization

These products are organized as a series based on their output capacity.

Item	Type No.		
	STK403-430	STK403-440	STK403-450
Output 1 (10%/1 kHz)	30 W × 6 ch	40 W × 6 ch	45 W × 6 ch
Output 2 (0.6%/20 Hz to 20 kHz)	20 W × 6 ch	25 W × 6 ch	30 W × 6 ch
Maximum supply voltage (No signal)	±36 V	±38 V	±40 V
Maximum supply voltage (6 Ω)	±34 V	±36 V	±38 V
Recommended supply voltage (6 Ω)	±23 V	±26 V	±28 V
Package	78.0 mm × 32.0 mm × 9.0 mm		

### Specifications

#### Maximum Ratings at $T_a = 25^\circ\text{C}$

Parameter	Symbol	Conditions	Ratings	Unit
Maximum supply voltage (No signal)	$V_{CC \max(0)}$		±38	V
Maximum supply voltage	$V_{CC \max(1)}$	$R_L \geq 6 \Omega$	±36	V
Minimum operating supply voltage	$V_{CC \min}$		±10	V
Maximum operation flow-in current (pin 23)	$I_{ST \text{ OFF max}}$		1.2	mA
Thermal resistance	$\theta_{j-c}$	Per power transistor	3.6	$^\circ\text{C/W}$
Junction temperature	$T_j \text{ max}$	Both the $T_j \text{ max}$ and the $T_c \text{ max}$ conditions must be met.	150	$^\circ\text{C}$
Operating IC substrate temperature	$T_c \text{ max}$		125	$^\circ\text{C}$
Storage temperature	$T_{stg}$		-30 to +125	$^\circ\text{C}$
Allowable load shorted time *4	$t_s$	$V_{CC} = \pm 26.0 \text{ V}$ , $R_L = 6 \Omega$ , $f = 50 \text{ Hz}$ , $P_O = 25 \text{ W}$ , 1ch drive	0.3	s

#### Operating Characteristics at $T_c = 25^\circ\text{C}$ , $R_L = 6 \Omega$ (noninductive load), $R_g = 600 \Omega$ , $V_G = 30 \text{ dB}$

Parameter	Symbol	Conditions*1				Ratings			Unit	
		$V_{CC}$ (V)	f (Hz)	$P_O$ (W)	THD (%)	min	typ	max		
Output power *1	$P_O$ (1)	±26.0	20 to 20 k		0.6	23	25		W	
	$P_O$ (2)	±26.0	1 k		10		40			
Total harmonic distortion *1	THD (1)	±26.0	20 to 20 k	5.0				0.6	%	
	THD (2)	±26.0	1 k	5.0			0.03			
Frequency characteristics	$f_L, f_H$	±26.0		1.0		+0 -3 dB	20 to 50 k		Hz	
Input impedance	$r_i$	±26.0	1 k	1.0			55		kΩ	
Output noise voltage *2	$V_{NO}$	±31.0				$R_g = 2.2 \text{ k}\Omega$		1.0	mVrms	
Quiescent current	$I_{CCO}$	±31.0				No loading	60	110	180	mA
Neutral voltage	$V_N$	±31.0					-70	0	+70	mV
Current flowing into pin 23 in standby mode *6	$I_{ST \text{ ON}}$	±26.0				$V_{23} = 5 \text{ V}$ , current limiting resistance: 6.2 kΩ			0	mA
Current flowing into pin 23 in operating mode *6	$I_{ST \text{ OFF}}$	±26.0					0.4	1.2	mA	

Notes: 1. 1ch drive

2. Unless otherwise noted, use a constant-voltage supply for the power supply used during inspection.
3. The output noise voltage values shown are peak values read with a VTVM. However, an AC stabilized (50 Hz) power supply should be used to minimize the influence of AC primary side flicker noise on the reading.
4. Use the transformer power supply circuit shown in the figure below for allowable load shorted time measurement and output noise voltage measurement.
5. Design applications so that the minus pre- $V_{CC}$  line (pin 17) is at the lowest potential at all times.
6. A limiting resistor that assures that the maximum operating current flowing into the standby pin (pin 23) does not exceed the maximum rating must be included in application circuits. This IC operates when a voltage higher than  $V_{BE}$  (about 0.6 V) is applied to the standby pin.

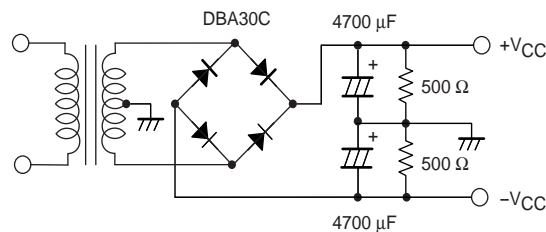

**Designated Transformer Power Supply (RP-25 equivalent)**

Internal Equivalent Circuit

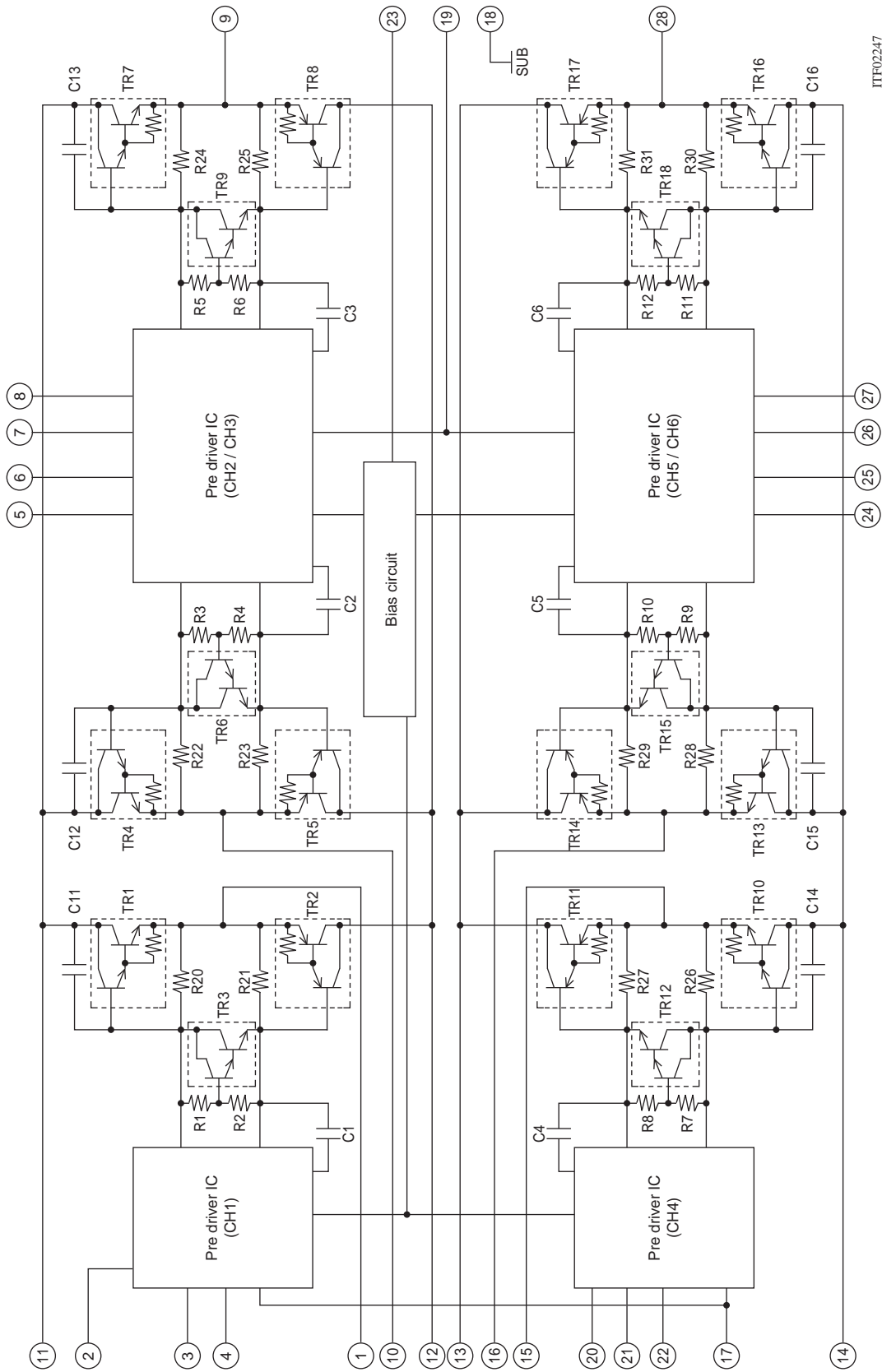

ITP02247

Sample Application Circuit

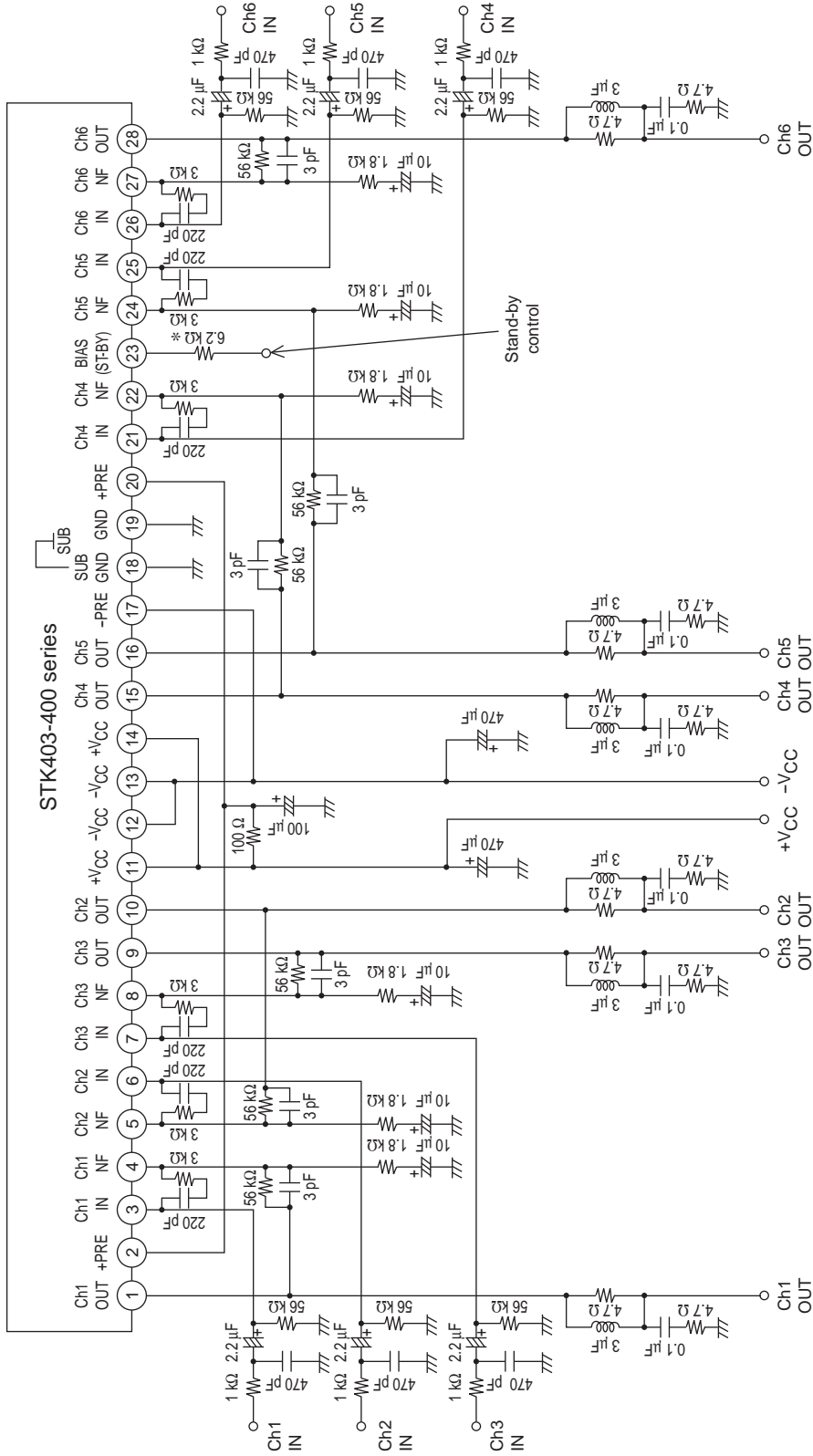

\*: Use a value for the limiting resistor that assures that the maximum operating current flowing into the standby pin (pin 23) does not exceed the maximum rating.

## Thermal Design Example

The heat sink thermal resistance,  $\theta_{c-a}$ , required to handle the total power dissipated within this hybrid IC is determined as follows.

Condition 1: The IC substrate temperature  $T_c$  must not exceed 125°C.

$$P_d \times \theta_{c-a} + T_a < 125^\circ\text{C} \dots (1)$$

$T_a$ : Guaranteed ambient temperature for the end product.

Condition 2: The junction temperature of each transistor must not exceed 150°C.

$$P_d \times \theta_{c-a} + P_d/N \times \theta_{j-c} + T_a < 150^\circ\text{C} \dots (2)$$

$N$ : Number of power transistors

$\theta_{j-c}$ : Thermal resistance per power transistor

We take the power dissipation in the power transistors to be  $P_d$  evenly distributed across those  $N$  power transistors.

If we solve for  $\theta_{c-a}$  in equations (1) and (2), we get the following inequalities.

$$\theta_{c-a} < (125 - T_a)/P_d \dots (1)'$$

$$\theta_{c-a} < (150 - T_a)/P_d - \theta_{j-c}/N \dots (2)'$$

Values that satisfy both these inequalities at the same time are the required heat sink thermal resistance values.

Determining the following specifications allows us to obtain the required heat sink thermal resistance from inequalities (1)' and (2)'.

- Supply voltage:  $V_{CC}$
- Load resistance:  $R_L$
- Guaranteed ambient temperature:  $T_a$

Example:

Assume that the IC supply voltage,  $V_{CC}$ , is  $\pm 26$  V,  $R_L$  is 6  $\Omega$ , and that the signal is a continuous sine wave. In this case, from the  $P_d - P_O$  characteristics, the maximum power will be 134 W for a signal with a frequency of 1 kHz.

For actual music signals, it is usual to use a  $P_d$  of 1/8 of  $P_{Omax}$ , which is the power estimated for continuous signals in this manner. (Note that depending on the particular safety standard used, a value somewhat different from the value of 1/8 used here may be used.)

That is:

$$P_d = 85 \text{ W (when } 1/8 P_{Omax} \text{ is } 3.1 \text{ W)}$$

The number,  $N$ , of power transistors in the hybrid IC's audio amplifier block is 12. Since the thermal resistance,  $\theta_{j-c}$ , per transistor is 3.6°C/W, the required heat sink thermal resistance,  $\theta_{c-a}$ , for a guaranteed ambient temperature of 50°C will be as follows.

$$\begin{aligned} \text{From inequality (1)': } \theta_{c-a} &< (125 - 50)/85 \\ &< 0.88 \end{aligned}$$

$$\begin{aligned} \text{From inequality (2)': } \theta_{c-a} &< (150 - 50)/85 - 3.6/12 \\ &< 0.87 \end{aligned}$$

Therefore, the thermal resistance that satisfies both these expressions at the same time is 0.87°C/W.

Note that this thermal design example assumes the use of a constant-voltage power supply, and is only provided as an example for reference purposes. Thermal designs must be tested in an actual end product.

Stand-by & Mute Sample Application Circuit

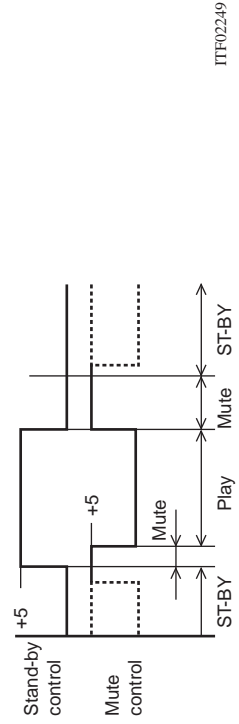
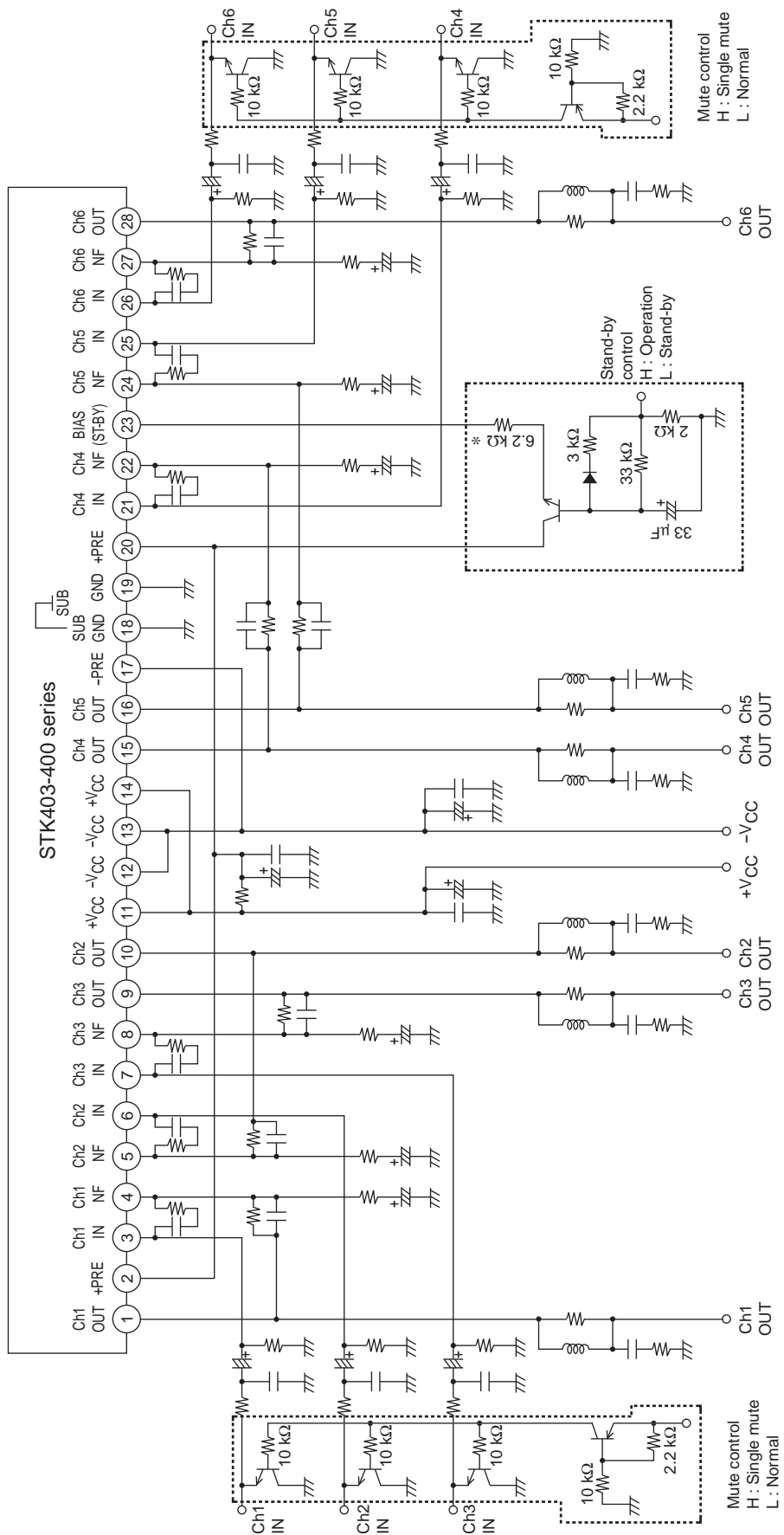

\*: Use a value for the limiting resistor that assures that the maximum operating current flowing into the standby pin (pin 23) does not exceed the maximum rating.

ITF02249

Standby Mode Control

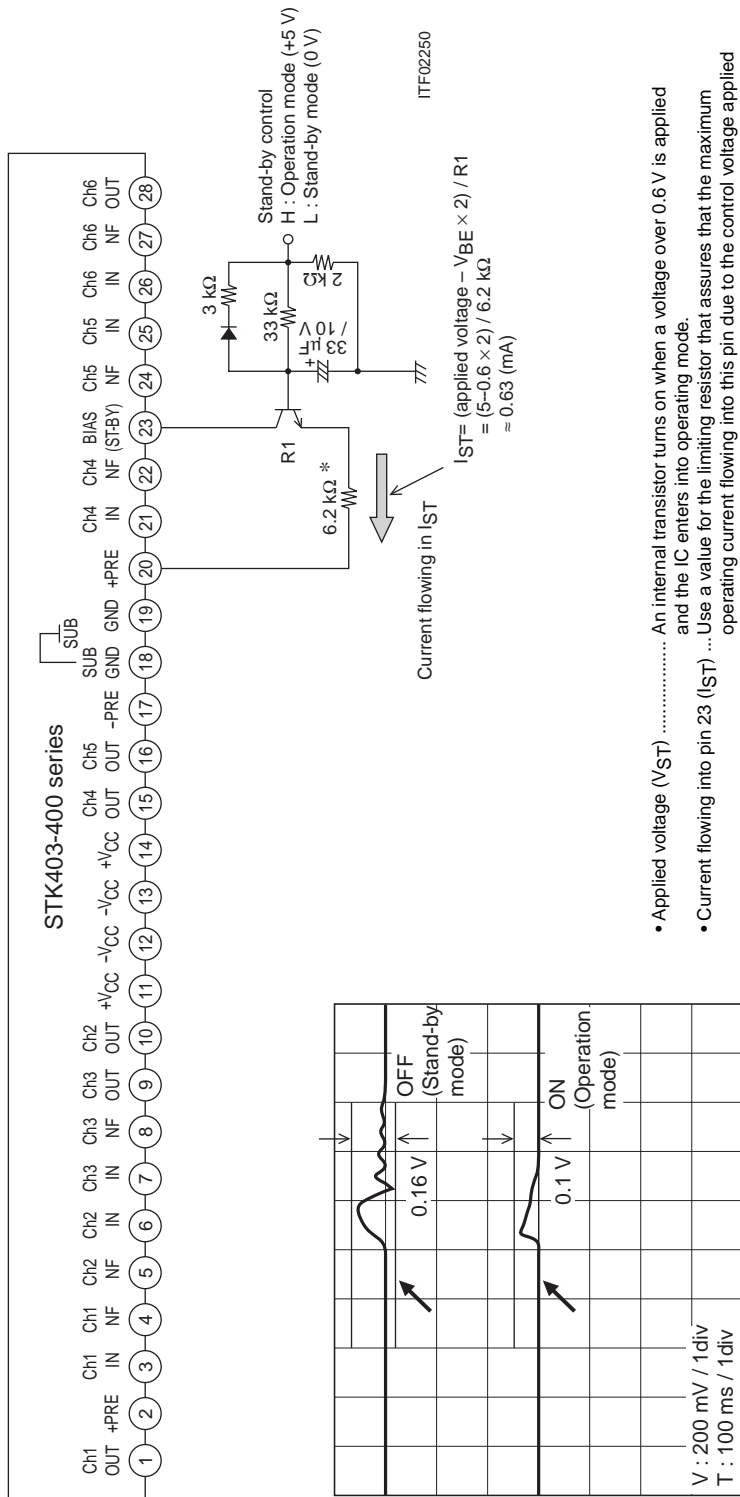

ITF02263

- Impulse noise that occurs at power on and power off can be reduced significantly by using a standby circuit.
- End product design is made easier by using a limiting resistor (\*) to match the control voltage provided by the microcontroller or other control circuit.
- Standby control is available by controlling the current (I<sub>ST</sub>) flowing into the standby pin (pin 23).

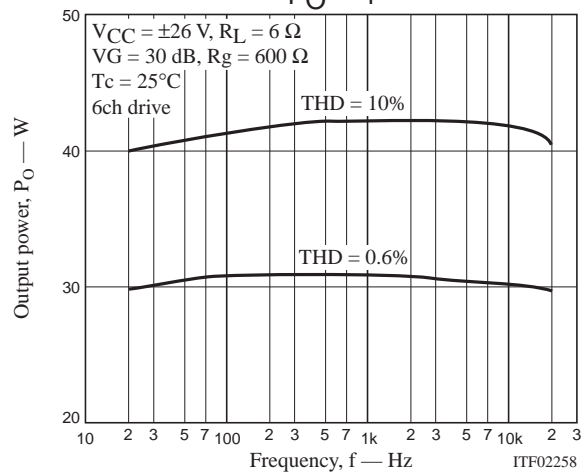
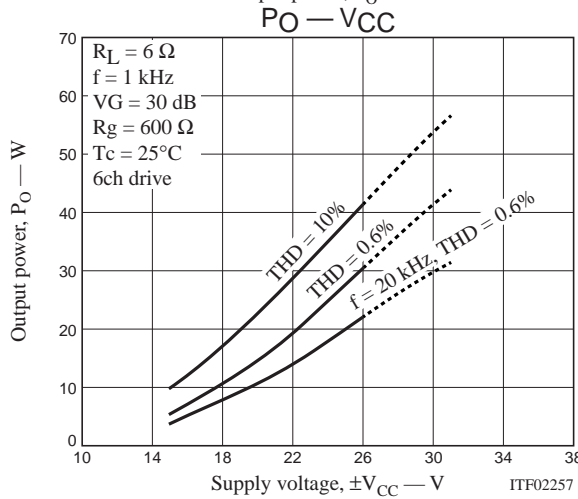
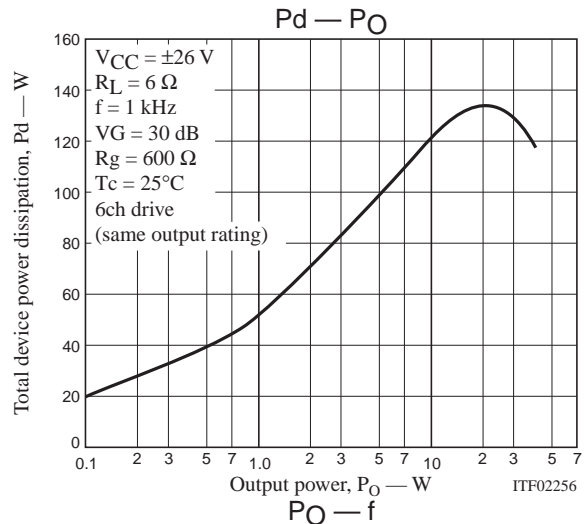
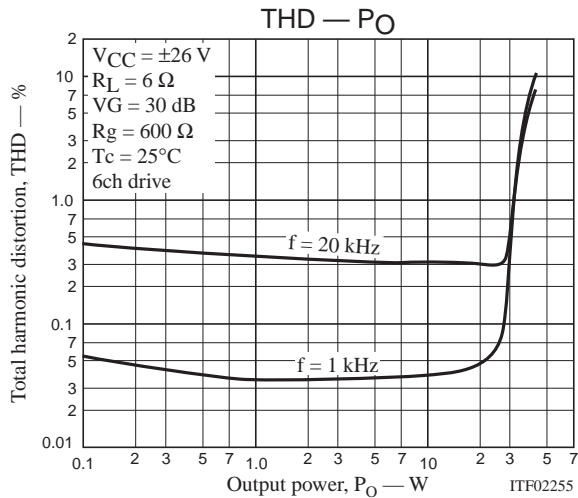

- Specifications of any and all SANYO products described or contained herein stipulate the performance, characteristics, and functions of the described products in the independent state, and are not guarantees of the performance, characteristics, and functions of the described products as mounted in the customer's products or equipment. To verify symptoms and states that cannot be evaluated in an independent device, the customer should always evaluate and test devices mounted in the customer's products or equipment.
- SANYO Electric Co., Ltd. strives to supply high-quality high-reliability products. However, any and all semiconductor products fail with some probability. It is possible that these probabilistic failures could give rise to accidents or events that could endanger human lives, that could give rise to smoke or fire, or that could cause damage to other property. When designing equipment, adopt safety measures so that these kinds of accidents or events cannot occur. Such measures include but are not limited to protective circuits and error prevention circuits for safe design, redundant design, and structural design.
- In the event that any or all SANYO products (including technical data, services) described or contained herein are controlled under any of applicable local export control laws and regulations, such products must not be exported without obtaining the export license from the authorities concerned in accordance with the above law.
- No part of this publication may be reproduced or transmitted in any form or by any means, electronic or mechanical, including photocopying and recording, or any information storage or retrieval system, or otherwise, without the prior written permission of SANYO Electric Co., Ltd.
- Any and all information described or contained herein are subject to change without notice due to product/technology improvement, etc. When designing equipment, refer to the "Delivery Specification" for the SANYO product that you intend to use.
- Information (including circuit diagrams and circuit parameters) herein is for example only; it is not guaranteed for volume production. SANYO believes information herein is accurate and reliable, but no guarantees are made or implied regarding its use or any infringements of intellectual property rights or other rights of third parties.

This catalog provides information as of February, 2004. Specifications and information herein are subject to change without notice.