

## SMD-codes

## DATABOOK

SMD-codes.  
3-pin cases active SMD  
semiconductor components  
marking codes.

- 47.000 semiconductor components SMD-codes:
- Diodes, Transistors, Integrated circuits
- Case pin assignment
- Pinout
- Marking style
- Schematic diagram
- Additional SMD info
- Case drawings
- Manufacturers



2024-2025 EDITION



<http://www.turuta.md>

ELECTRONICS COMPONENTS

**Eugeniu Turuta Martin Turuta**

**SMD-codes.**

**3-pin cases active SMD semiconductor components  
marking codes.**

**DATABOOK**

## CONTENTS

Abbreviation .....	3
Section 1. 3-pin cases SMD semiconductor components .....	6
Section 2. Conventional case drawing. ....	667
Section 3. Pinout (table) .....	669
Section 4. SMD-codes marking style .....	682
Section 5. SMD-codes marking attribute .....	686
Section 6. Additional production data info .....	692
Section 7. Case drawings .....	699
Section 8. Sample schematic diagram .....	703
Section 9. Manufacturers name, logo and web page URL .....	705



## Introduction

At earlier eighties began a trend to replace a traditional through-hole technique with the surface mounted technology (SMT) using surface mounted devices (SMD). The SMT, although intended in principle for automatic manufacturing only expand more and more, even into a hobby world. This trend will continue, because many new components are available in SMD versions only. The SMT technique opens advantages and new applications through miniaturising of the components and increasing of reliability. The industry standard unfortunately allows that most of the SMD components does not have a clear description. Since a tiny size of the components, they are labelled with one, two or more character or graphic SMD code. Thus it is necessary to take into account that the colour and (or) placing of alphanumeric or graphic symbols are also important. Therefore a sure identification of the components is impossible without appropriate technical documentation. Moreover the polarity and pin - outs of different components could be not identified without data sheets.

Identifying the manufacturers type number of an SMD device from the package code can be a difficult task. Unfortunately, each device code is not necessarily unique.

For various manufacturers it is possible to place different devices in the same case with the same SMD-code. For example, with a **6H** SMD-code in a SOT-23 case might be either a npn-transistor **BC818** (CDIL) or a capacitance-diode **FMMV2104** (Zetex) or a n-channel JFET transistor **MMBF5486** (Motorola) or a npn-digital transistor **MUN2131** (Motorola) or a npn-digital transistor **UN2117** (Panasonic) or a CMOS-integrated circuit- voltage detector with reset output **R3131N36EA** (Ricoh). Even the same manufacturer may use the same code for different devices.

To identify a particular SMD device, is necessary to identify the manufacturer, package type and note the SMD code printed on the device.

The identification of the manufacturer is possible only if on the case are printed the manufacturer's logos, but it not always happens. Besides, sometimes, it is possible to determine the manufacturer with indirect tags. Many recent ON Semiconductor devices have a small superscript letter after the device code, such as **SA<sup>c</sup>** (this smaller letter is merely a month of manufacture code). Infineon devices usually have a lower case '**s**' (**ATs**, **LOs**). NXP (Philips) devices usually have a lower case '**p**' (**AHp**, **Z1p**, **pB0**) or '**'**' (**DQ-**, **-ZS**) for the devices made in Hong Kong, '**t**' (**tT9**, **Y7t**) for the devices made in Malaysia, "**W**" (**WT9**, **Y7W**) for the devices made in China. In section 19 are submitted the logos of the SMD devices manufacturers.

The package type is another problem for the identification of SMD devices. The different manufacturers can designate identical cases concerning by the various standards (or concerning by the internal system). Besides, the various cases can have an identical kind (form) and differ only by sizes. This distinction of sizes so it is not enough, that can be is measured only by special measuring devices.

Compliance with the name and type of cases from different manufacturers is solved by applying in the column "Case" an equivalent type name for equivalent cases.

In addition to SMD-code, upper case may be put padding alpha-numeric information (usually by another font or size of characters, also may be by other arrangement). Relationship position of the SMD-code and padding information have defined as style and show in the column "Style"

In the following tables sections the SMD semiconductor components - irrelevant as to whether it is dealing with transistors, diodes, integrated circuits etc. are placed in separate tables according to numbers of terminals and (or) type of cases and are listed in alpha-numeric order by SMD-codes.

### Column 1 ("SMD-Code")

### Column 2 ("Type")

The type designations correspond to those of the respective manufacturer documentations.

### Column 3 ("Function")

Short definition of the semiconductor component.

Used abbreviations:

BM-IC	Battery Management integrated circuit	LDR-IC	LED driver integrated circuit
BR	Bridge Rectifier	Lin-IC	Linear integrated circuit
C-diode	Capacitance diode (varactor, varicap)	LVR-IC	Linear voltage regulator integrated circuit
CMOS-Log	CMOS logic integrated circuit	LVR/Vdet-IC	Linear voltage regulator/Voltage detector combined integrated circuit
Comp-IC	Voltage comparator integrated circuit	MMIC	Monolithic Microwave Integrated Circuit
DC/DC-IC	DC/DC voltage converter integrated circuit	-MOSFET	Metal-Oxide-Semiconductor FET
ESDP-diode	ElectroStatic Discharge Protection diode	-MESFET	MEtal-Semiconductor FET
ESD-Prot	ElectroStatic Discharge Protection thyristor	n-	n-channel junction transistor
-FET	Field Effect Transistor	n/p-	n-channel and p-channel transistors area
HEMT	High electron mobility transistors	Op-IC	Operational amplifier integrated circuit
H-IC	Hall-effect sensor integrated circuit	p-	p-channel junction transistor
HSPS-IC	High-side power switch integrated circuit	PDS-IC	Power distribution switch integrated circuit
IGBT	Insulated Gate Bipolar Transistor	PHEMT	Pseudomorphic high electron mobility transistors
IGBT+Di	Insulated Gate Bipolar Transistor with antiparallel diode	PIN-diode	Diode with a wide, undoped intrinsic semiconductor region
		PSW-IC	Power Switch IC
		Si-diode	Silicon diode
		SiGe-diode	Silicon/Germanium diode
		Si-npn	Silicon npn transistor
		Si-n/p	Silicon npn and pnp transistors area
		Si-npn-Darl	Silicon npn Darlington transistor

**SECTION 1**  
**3-pin case SMD semiconductor components**

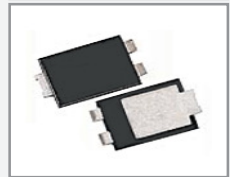
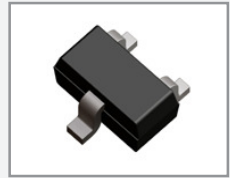
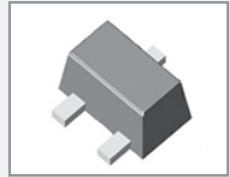
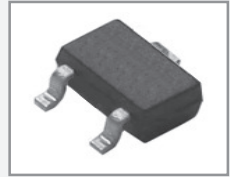

SMD code	Type	Function	Case	Style	Short description	Atr	A.d.	Pin	Sch	Mnf
-	ELM7548CEB	Vdet-IC	SC-70	3d	4.8V±2%, +Reset PPO	B23a	23	16vdb	VD7	Elm
-	ELM7548NEB	Vdet-IC	SC-70	3d	4.8V±2%, +Reset ODO	B23a	06	16vdb	VD6	Elm
#	ELM7541CEB	Vdet-IC	SC-70	3d	4.1V±2%, +Reset PPO	B23a	23	16vdb	VD7	Elm
#	ELM7541NEB	Vdet-IC	SC-70	3d	4.1V±2%, +Reset ODO	B23a	06	16vdb	VD6	Elm
*	ELM7546CEB	Vdet-IC	SC-70	3d	4.6V±2%, +Reset PPO	B23a	23	16vdb	VD7	Elm
*	ELM7546NEB	Vdet-IC	SC-70	3d	4.6V±2%, +Reset ODO	B23a	06	16vdb	VD6	Elm
*	ELM7547NEB	Vdet-IC	SC-70	3d	4.7V±2%, +Reset ODO	B23a	06	16vdb	VD6	Elm
.038	MC1038	n-MOSFET	SC-89-3	3a	GP, 20V, 750mA, 300mW, 0.24Ω(600mA), 3.8/252us	-	-	16fh	-	Mep
/	ELM7554CEB	Vdet-IC	SC-70	3d	5.4V±2%, +Reset PPO	B23a	23	16vdb	VD7	Elm
/	ELM7554NEB	Vdet-IC	SC-70	3d	5.4V±2%, +Reset ODO	B23a	06	16vdb	VD6	Elm
+	ELM7547CEB	Vdet-IC	SC-70	3d	4.7V±2%, +Reset PPO	B23a	23	16vdb	VD7	Elm
+FZVC	LM4040CEM3-5.0V+T	Vref-IC	SOT-23	3a	uPower, Precision, Shunt, 5.00V±0.5%	-	-	16dk	RF1	Max
+P2	BFR92A	Si-npn	SOT-23	3a	UHF-A-Band, 20V, 25mA, 300mW, B>40, >5GHz	-	-	16ta	-	Vs
+P5	BFR92AR	Si-npn	SOT-23	3a	UHF-A-Band, 20V, 25mA, 300mW, B>40, >5GHz	-	-	16te	-	Vs
+R2	BFR93A	Si-npn	SOT-23	3a	UHF-A-Band, 15V, 30mA, 300mW, B>40, >5GHz	-	-	16ta	-	Sil
+R5	BFR93AR	Si-npn	SOT-23	3a	UHF-A-Band, 15V, 30mA, 300mW, B>40, >5GHz	-	-	16te	-	Sil
<	ELM7553CEB	Vdet-IC	SC-70	3d	5.3V±2%, +Reset PPO	B23a	23	16vdb	VD7	Elm
<	ELM7553NEB	Vdet-IC	SC-70	3d	5.3V±2%, +Reset ODO	B23a	06	16vdb	VD6	Elm
=	ELM7544CEB	Vdet-IC	SC-70	3d	4.4V±2%, +Reset PPO	B23a	23	16vdb	VD7	Elm
=	ELM7544NEB	Vdet-IC	SC-70	3d	4.4V±2%, +Reset ODO	B23a	06	16vdb	VD6	Elm
>	ELM7549CEB	Vdet-IC	SC-70	3d	4.9V±2%, +Reset PPO	B23a	23	16vdb	VD7	Elm
>	ELM7549NEB	Vdet-IC	SC-70	3d	4.9V±2%, +Reset ODO	B23a	06	16vdb	VD6	Elm
0	AX6904IA	Vdet-IC	SC-70-3L	3be	4.25V±1.5%, +Reset PPO	-	27	16vdb	VD7	Axl
0.	ELM7552CEB	Vdet-IC	SC-70	3d	5.2V±2%, +Reset PPO	B23a	23	16vdb	VD7	Elm
0.	ELM7552NEB	Vdet-IC	SC-70	3d	5.2V±2%, +Reset ODO	B23a	06	16vdb	VD6	Elm
00	AP8822C-40GA	Vdet-IC	SOT-23	3ba	4.0V±2%, -Reset PPO, Rdt=200ms, H-free	B05e	-	16vdc	VD7	Anw
00	AP8822C-40GT	Vdet-IC	SC-70	3ba	4.0V±2%, -Reset PPO, Rdt=200ms, H-free	B05e	-	16vdc	VD7	Anw
00	AP8822C-40PA	Vdet-IC	SOT-23	3ba	4.0V±2%, -Reset PPO, Rdt=200ms	B05	-	16vdc	VD7	Anw
00	AP8822C-40PT	Vdet-IC	SC-70	3ba	4.0V±2%, -Reset PPO, Rdt=200ms	B05	-	16vdc	VD7	Anw
00	EC95810C40B1N	Vdet-IC	SOT-23-3L	3dd	4.0V±2%, -Reset PPO, Rdt=200ms	B38	24	16vdc	VD7	Ecm
00	EC95810C40C1N	Vdet-IC	SC-70-3L	3dd	4.0V±2%, -Reset PPO, Rdt=200ms	B38	24	16vdc	VD7	Ecm
00	ELM7510CBB	Vdet-IC	SOT-23	3d	1.0V±2%, +Reset PPO	B23	23	16vdb	VD7	Elm
00	ELM7510NBB	Vdet-IC	SOT-23	3d	1.0V±2%, +Reset ODO	B23	06	16vdb	VD6	Elm
00	ST7400	n-MOSFET	SOT-323	3bc	Sw, 30V, 2.8A, 1.25W, 77 mΩ(2.8A), 2.5/20ns	-	-	16fh	-	Sta
005	SSTPAD5	Si-diode	SOT-23	3a	Dual, Low-leakage, 10mA, 350mW, Vf<1.5V(5mA), Ir=5pA, 2pF	-	-	16fj	-	Six
01	AP8822C-41GA	Vdet-IC	SOT-23	3ba	4.1V±2%, -Reset PPO, Rdt=200ms, H-free	B05e	-	16vdc	VD7	Anw
01	AP8822C-41GT	Vdet-IC	SC-70	3ba	4.1V±2%, -Reset PPO, Rdt=200ms, H-free	B05e	-	16vdc	VD7	Anw
01	AP8822C-41PA	Vdet-IC	SOT-23	3ba	4.1V±2%, -Reset PPO, Rdt=200ms	B05	-	16vdc	VD7	Anw
01	AP8822C-41PT	Vdet-IC	SC-70	3ba	4.1V±2%, -Reset PPO, Rdt=200ms	B05	-	16vdc	VD7	Anw
01	EC95810C41B1N	Vdet-IC	SOT-23-3L	3dd	4.1V±2%, -Reset PPO, Rdt=200ms	B38	24	16vdc	VD7	Ecm
01	EC95810C41C1N	Vdet-IC	SC-70-3L	3dd	4.1V±2%, -Reset PPO, Rdt=200ms	B38	24	16vdc	VD7	Ecm
01	ELM7511CBB	Vdet-IC	SOT-23	3d	1.1V±2%, +Reset PPO	B23	23	16vdb	VD7	Elm
01	ELM7511NBB	Vdet-IC	SOT-23	3d	1.1V±2%, +Reset ODO	B23	06	16vdb	VD6	Elm
01	GF2301	p-MOSFET-e	SOT-23	3a	GP, 20V, 2.3A, 1.25W, Rds=95mΩ(2.3A), 5/95ns	-	-	16fh	-	Gse
01	PDTA143EE	Si-pnp-Digi	SOT-416	3a	Sw, 50V, 100mA, 150mW, R1/R2=4.7k/4.7k	-	-	16ta	-	Nxp
01	PDTA143EK	Si-pnp-Digi	SC-59	3f	Sw, 50V, 100mA, 250mW, R1/R2=4.7k/4.7k	B43	-	16ta	-	Nxp
010	SO918R	Si-npn	SOT-23	3a	VHF/UHF, 15V, 50mA, B>20, 600MHz	-	-	16te	-	Ste
010	SSTPAD10	Si-diode	SOT-23	3a	Dual, Low-leakage, 10mA, 350mW, Vf<1.5V(5mA), Ir=10pA, 2pF	-	-	16fj	-	Six
01A	APR3001-15A	Vdet-IC	SOT-23	3b	1.5V±1.5%, -Reset PPO	-	-	16vdb	VD7	Anp
01A	RA101C	Si-pnp-Digi	SOT-23	3a	Sw, 50V, 100mA, 200mW, 250MHz, R1/R2=47k/47k	-	-	16ta	-	San
01B	APR3001-17A	Vdet-IC	SOT-23	3b	1.75V±1.5%, -Reset PPO	-	-	16vdb	VD7	Anp
01C	APR3001-23A	Vdet-IC	SOT-23	3b	2.32V±1.5%, -Reset PPO	-	-	16vdb	VD7	Anp
01C	RC101C	Si-npn-Digi	SOT-23	3a	Sw, 50V, 100mA, 200mW, 250MHz, R1/R2=47k/47k	-	-	16ta	-	San
01D	APR3001-26A	Vdet-IC	SOT-23	3b	2.63V±1.5%, -Reset PPO	-	-	16vdb	VD7	Anp
01E	APR3001-29A	Vdet-IC	SOT-23	3b	2.93V±1.5%, -Reset PPO	-	-	16vdb	VD7	Anp
01F	APR3001-30A	Vdet-IC	SOT-23	3b	3.08V±1.5%, -Reset PPO	-	-	16vdb	VD7	Anp
01G	APR3001-39A	Vdet-IC	SOT-23	3b	3.9V±1.5%, -Reset PPO	-	-	16vdb	VD7	Anp
01H	APR3001-43A	Vdet-IC	SOT-23	3b	4.38V±1.5%, -Reset PPO	-	-	16vdb	VD7	Anp
01J	APR3001-46A	Vdet-IC	SOT-23	3b	4.63V±1.5%, -Reset PPO	-	-	16vdb	VD7	Anp
02	2N7002	n-MOSFET	SOT-23	3ba	TMOS, 60V, 115mA, 225mW, <7.5Ω(500mA), 20/40ns	B19	14	16fh	-	Frm
02	2N7002	n-MOSFET	SOT-23	3ba	TMOS, 60V, 115mA, 225mW, <7.5Ω(500mA), 20/40ns	B19b	14	16fh	-	Sec
02	2N7002	n-MOSFET	SOT-23	3ba	TMOS, 60V, 115mA, 225mW, <7.5Ω(500mA), 20/40ns, H-free	B19a	14	16fh	-	Frm
02	AP8822C-42GA	Vdet-IC	SOT-23	3ba	4.2V±2%, -Reset PPO, Rdt=200ms, H-free	B05e	-	16vdc	VD7	Anw
02	AP8822C-42GT	Vdet-IC	SC-70	3ba	4.2V±2%, -Reset PPO, Rdt=200ms, H-free	B05e	-	16vdc	VD7	Anw
02	AP8822C-42PA	Vdet-IC	SOT-23	3ba	4.2V±2%, -Reset PPO, Rdt=200ms	B05	-	16vdc	VD7	Anw
02	AP8822C-42PT	Vdet-IC	SC-70	3ba	4.2V±2%, -Reset PPO, Rdt=200ms	B05	-	16vdc	VD7	Anw
02	BSX39	Si-npn	SOT-23	3a	Sw, Driver, 45V, 0.2A, <12/18ns	-	-	16te	-	Mot
02	EC95810C42B1N	Vdet-IC	SOT-23-3L	3dd	4.2V±2%, -Reset PPO, Rdt=200ms	B38	24	16vdc	VD7	Ecm
02	EC95810C42C1N	Vdet-IC	SC-70-3L	3dd	4.2V±2%, -Reset PPO, Rdt=200ms	B38	24	16vdc	VD7	Ecm
02	ELM7512CBB	Vdet-IC	SOT-23	3d	1.2V±2%, +Reset PPO	B23	23	16vdb	VD7	Elm



SMD code	Type	Function	Case	Style	Short description	Atr	A.d.	Pin	Sch	Mnf
ZVp	PDTD114EU	Si-npn-Digi	SOT-323	3a	Sw, 50V, 500mA, 300mW, R1/R2=10k/10k	-	-	16ta	-	NxH
ZVt	PDTD114EU	Si-npn-Digi	SOT-323	3a	Sw, 50V, 500mA, 300mW, R1/R2=10k/10k	-	-	16ta	-	NxM
ZVW	PDTD114EU	Si-npn-Digi	SOT-323	3a	Sw, 50V, 500mA, 300mW, R1/R2=10k/10k	-	-	16ta	-	NxC
ZW	55GN01CA	Si-pnp	CP	3a	RF, 20V, 70mA, 200mW, B=100..180, 4.5GHz	-	-	16ta	-	Ons
ZW	CZMK9V1	Z-diode	SOT-23	3a	Dual, 9.1V±5%, Izt=5mA, 300mW	-	-	16dg	-	Cdi
ZW	TZT9V1CW	Z-diode	SOT-23	3a	Dual, 8.5..9.6V, Izt=5mA, Zzt=15Ω, 300mW	-	-	16dg	-	Ttr
ZWA	KN4403S	Si-pnp	SOT-23	3f	GP, Sw, 40V, 600mA, 350mW, B=100..300, 250MHz	-	-	16ta	-	Kec
ZX	CZMK10	Z-diode	SOT-23	3a	Dual, 10V±5%, Izt=5mA, 300mW	-	-	16dg	-	Cdi
ZX	TZT10CW	Z-diode	SOT-23	3a	Dual, 9.4..10.6V, Izt=5mA, Zzt=20Ω, 300mW	-	-	16dg	-	Ttr
ZY	2SA1182-Y	Si-pnp	SC-59	3a	AF, 35V, 500mA, 150mW, B=120..240, 200MHz	-	-	16ta	-	Tos
ZY	2SA1588-Y	Si-pnp	SC-70	3a	AF-Drv, Sw, 35V, 500mA, 100mW, B=120..240, 200MHz	-	-	16ta	-	Tos
ZY	2SC4047	Si-npn-Digi	CP	3a	Sw, 50V, 100mA, 200mW, 250MHz, B>70, R1/R2=10k/47k	-	-	16ta	-	San
ZY	CZMK11	Z-diode	SOT-23	3a	Dual, 11V±5%, Izt=5mA, 300mW	-	-	16dg	-	Cdi
ZY	KTA2015-Y	Si-pnp	USM	3f	AF, Sw, 35V, 500mA, 100mW, B=120..240, 200MHz	-	-	16ta	-	Kec
ZY	TZT11CW	Z-diode	SOT-23	3a	Dual, 10.4..11.6V, Izt=5mA, Zzt=20Ω, 300mW	-	-	16dg	-	Ttr
ZY-	2SK3000	n-MOSFET	SOT-23	3a	V-MOS, LogL, 40V, 1A, <0.5Ω(0.45A), In, Rgate	-	-	16fh	-	Ren
ZZ	CZMK12	Z-diode	SOT-23	3a	Dual, 12V±5%, Izt=5mA, 300mW	-	-	16dg	-	Cdi
ZZ	TZT12CW	Z-diode	SOT-23	3a	Dual, 11.4..12.7V, Izt=5mA, Zzt=25Ω, 300mW	-	-	16dg	-	Ttr
ZZ-	2SK2980	n-MOSFET	MPAK	3a	V-MOS, LogL, 30V, 1A, <0.28Ω(0.5A)	B09	-	16fh	-	Ren
ZZ1	2BZX84C4V7A	Z-diode	SOT-23	3a	4.4..5.0V, Zzt=80Ω, Izt=5mA, 225mW	B14	-	16dc	-	Dic
ZZ1	CMPZDA4V7	Z-diode	SOT-23	3a	Dual, 4.7V±2.5%, If=10mA, 350mW	-	-	16df	-	Cen
ZZ2	2BZX84C5V1A	Z-diode	SOT-23	3a	4.8..5.4V, Zzt=60Ω, Izt=5mA, 225mW	B14	-	16dc	-	Dic
ZZ2	CMPZDA5V1	Z-diode	SOT-23	3a	Dual, 5.1V±2.5%, If=10mA, 350mW	-	-	16df	-	Cen
ZZ3	2BZX84C5V6A	Z-diode	SOT-23	3a	5.2..6.0V, Zzt=40Ω, Izt=5mA, 225mW	B14	-	16dc	-	Dic
ZZ3	CMPZDA5V6	Z-diode	SOT-23	3a	Dual, 5.6V±2.5%, If=10mA, 350mW	-	-	16df	-	Cen
ZZ4	2BZX84C6V2A	Z-diode	SOT-23	3a	5.8..6.6V, Zzt=10Ω, Izt=5mA, 225mW	B14	-	16dc	-	Dic
ZZ4	CMPZDA6V2	Z-diode	SOT-23	3a	Dual, 6.2V±2.5%, If=10mA, 350mW	-	-	16df	-	Cen
ZZ5	2BZX84C6V8A	Z-diode	SOT-23	3a	6.4..7.2V, Zzt=15Ω, Izt=5mA, 225mW	B14	-	16dc	-	Dic
ZZ5	CMPZDA6V8	Z-diode	SOT-23	3a	Dual, 6.8V±2.5%, If=10mA, 350mW	-	-	16df	-	Cen
ZZ6	2BZX84C7V5A	Z-diode	SOT-23	3a	7.0..7.9V, Zzt=15Ω, Izt=5mA, 225mW	B14	-	16dc	-	Dic
ZZ6	CMPZDA7V5	Z-diode	SOT-23	3a	Dual, 7.5V±2.5%, If=10mA, 350mW	-	-	16df	-	Cen
ZZ7	2BZX84C8V2A	Z-diode	SOT-23	3a	7.7..8.7V, Zzt=15Ω, Izt=5mA, 225mW	B14	-	16dc	-	Dic
ZZ7	CMPZDA8V2	Z-diode	SOT-23	3a	Dual, 8.2V±2.5%, If=10mA, 350mW	-	-	16df	-	Cen
ZZ8	2BZX84C9V1A	Z-diode	SOT-23	3a	8.5..9.6V, Zzt=15Ω, Izt=5mA, 225mW	B14	-	16dc	-	Dic
ZZ8	CMPZDA9V1	Z-diode	SOT-23	3a	Dual, 9.1V±2.5%, If=10mA, 350mW	-	-	16df	-	Cen
ZZ9	2BZX84C10A	Z-diode	SOT-23	3a	9.4..10.6V, Zzt=20Ω, Izt=5mA, 225mW	-	-	16dc	-	Dic
ZZ9	CMPZDA10V	Z-diode	SOT-23	3a	Dual, 10V±2.5%, If=10mA, 350mW	-	-	16df	-	Cen
ZZL	UM810ADP	Vdet-IC	SC-70-3	3ca	2.1V±1%, +Reset PPO	-	-	16vdc	VD7	Uns
ZZM	UM810AEP	Vdet-IC	SC-70-3	3ca	2.0V±1%, +Reset PPO	-	-	16vdc	VD7	Uns
ZZR	HWD809REX	Vdet-IC	SC-70	3a	2.63V±2%, -Reset PPO	-	-	16vdc	VD7	Csm
ZZY	UM810ZP	Vdet-IC	SC-70-3	3ca	2.32V±1%, +Reset PPO	-	-	16vdc	VD7	Uns



**SECTION 2**  
Conventional case drawings. Pin assignment

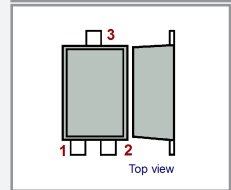
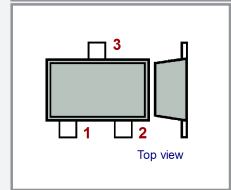
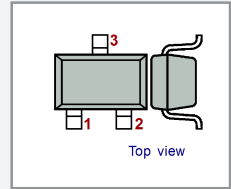



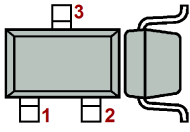

Top view

16

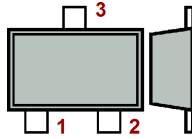

Top view

18

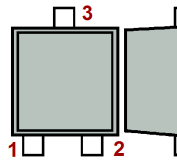

Top view

19

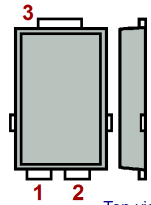

Top view

76

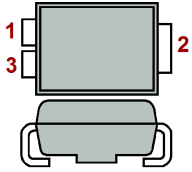

Top view

88

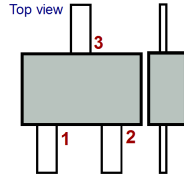

121

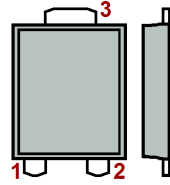

Top view

122

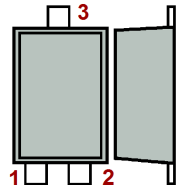

Top view

139

**SECTION 3**  
**Pinout (table)**



	PIN 1	PIN2	PIN3	PIN4	PIN5	PIN6	PIN7	PIN8
a0	GND	Output	Vcc	+Input	-Input	-	-	-
a1	GND	GND	Input	GND	GND	Vcc/Output	-	-
a2	N/C	Anode	Cathode	N/C	Adjust	-	-	-
a3	CE	GND	Vinput	Voutput	Adjust	N/C	-	-
a4	CE	Vinput	Voutput	Switch	GND	Feedback	-	-
a5	No data.	See datash.	See sch	-	-	-	-	-
a7	CE	GND	SSC	Vinput	Voutput	-	-	-
a8	Test	GND	Tdet	N/C	Vcc	-	-	-
a9	Tdet	GND	Test	Vcc	-	-	-	-
aa	Input	GND	Vcc/Output	GND	-	-	-	-
aa*	A1=CE/MODE	A3=Voutput	B2=Lx	C1=Vinput	C3=GND	-	-	-
ab	Input	GND	GND	Output	GND	Vcc	-	-
ab*	A1=CE/MODE	A3=Feedb.	B2=Lx	C1=Vinput	C3=GND	-	-	-
ac	Vcc	GND	Input	GND	GND	Output	GND	GND
ac*	A1-CE	A2=Vinput	B1=GND	B2=Voutput	-	-	-	-
ad	Input	GND	Vcc	Output	GND	-	-	-
ae	Input	Vcc	GND	Output	GND	GND	-	-
af	N/C	Vinput	N/C	GND	N/C	Voutput	N/C	N/C
ag	Contact	Contact	N/C	-	-	-	-	-
ah	Emitter	Emitter	Base	Emitter	Emitter	Collector	-	-
ai	GND	Vcc	Input	Output	-	-	-	-
aj	GND	Vcc/Vout	GND	Input	-	-	-	-
ak	N/C	Cathode	Anode	-	-	-	-	-
am	Vcc/Output	GND	Input	GND	-	-	-	-
an	Output	GND	Input	Vcc	GND	-	-	-
ao	Cath.(Anode)	N/C	Cath.(Anode)	An.(Cath.)	-	-	-	-
ap	Cathode	N/C	Cathode	Anode	-	-	-	-
aq	Contact	N/C	Contact	-	-	-	-	-
ar	Contact	Contact	-	-	-	-	-	-
as	Emitter	Emitter	N/C	Base	Collector	Collector	Collector	Collector
at	Cathode	Gate	Anode	-	-	-	-	-
au	CE	SS	Voutput	Vinput	GND	Vbias	-	-
av	Vbias	GND	Vinput	Voutput	SS	CE	-	-
aw	CE	Ilim	Voutput	Vinput	GND	Vbias	-	-
ax	Vbias	GND	Vinput	Voutput	Ilim	CE	-	-
ax*	A1=CE1	A2=Voutput1	B1=GND	B2=Vinput	C1=CE2	C2=Voutput2	-	-
ay*	A1=Voutput2	A2=Vcc	A3=Voutput1	B1=CE2	B2=GND	B3=CE1	-	-
az	Vinput	N/C	Voutput	N/C	N/C	N/C	GND	CE
b0	IN1	POS	Vin	Vout	CE	GND	IN2	NEG
b1	Terminal	Gate	Terminal	-	-	-	-	-
ba	Anode/Cath.	Anode/Cath.	-	-	-	-	-	-
ba*	A1=GND	A2=Voutput	B1=CE	B2=Vinput	-	-	-	-
bb	Cathode1	Cathode2	Cathode3	Anode3	Anode2	Anode1	-	-
bb*	A1=GND	A2=CE	B1=Voutput	B2=Vinput	-	-	-	-
bc*	A1=Vinput	A2=Voutput	B1=CE	B2=GND	-	-	-	-
bd	Cathode	Cathode	Anode	-	-	-	-	-
bd*	A1=GND	A2=Vcc	B1=Reset	B2=MR	-	-	-	-
be*	A1=CE	A3=Cb	B2=GND	C1=Voutput	C3=Vinput	-	-	-
bf*	A1=Output L	A2=GND	A3=Output R	B1=Input L	B3=Input R	C1=Shutdown	C2=Vcc	C3=Cext
bg	Cathode1	Cathode2	Anode2	N/C	Anode1	-	-	-
bg*	A1=Voutput	A2=Vinput	B1=Adj	B2=CE	C1=GND	C2=Vbias	-	-
bh	Anode1	Com. Cath.	Anode2	Anode3	Anode4	-	-	-
bh*	A1=GND	A3=CE	B2=Cb	C1=Voutput	C3=Vinput	-	-	-
bi	Anode	Cathode	Anode	Anode	Cathode	Anode	-	-
bj*	A1=Voutput	A2=Vinput	B2=GND	C1=CE	C2= Vbias	-	-	-
bk*	A1=Voutput	A2=Vinput	B1=GND	B2=CE	-	-	-	-
bm1	N/C	Cout	Dout	GND	V+	V-	-	-
bm2	V-	V+	GND	Dout	Cout	-	-	-
bn	OVP	Vinput	CE	A GND	N/C	Feedback	Switching	P GND
bp	Cathode	Cathode	Anode	Anode	Cathode	Cathode	-	-
bq	GND	Voutput	Lx	-	-	-	-	-
br	GND	Voutput	Ext	-	-	-	-	-



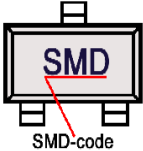
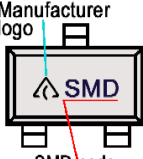
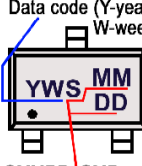
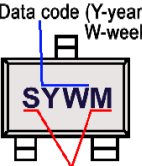
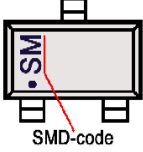
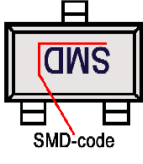
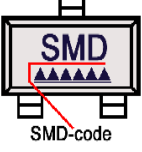
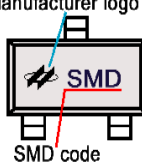
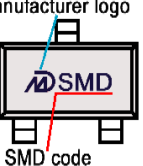
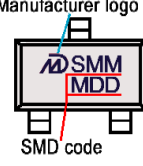
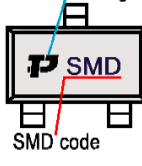
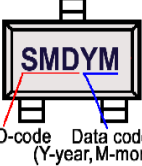
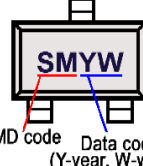
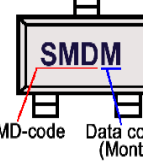
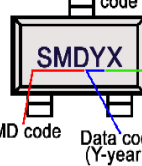
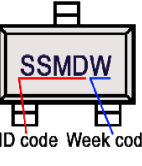
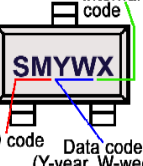
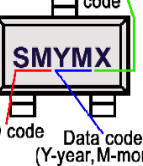
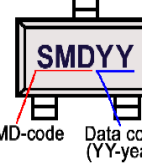
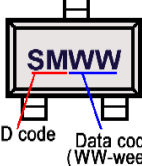
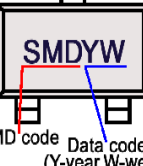
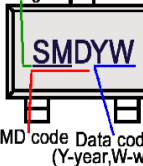
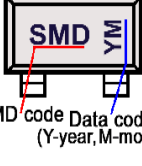
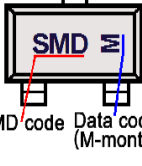

**SECTION 4**  
**3-pin cases SMD-code marking style**

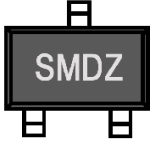
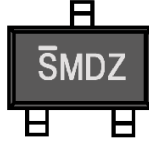

<p><b>3a</b></p>  <p>SMD-code</p>	<p><b>3aa</b></p>  <p>Manufacturer logo</p> <p>SMD-code</p>	<p><b>3ab</b></p>  <p>Data code (Y-year, W-week)</p> <p>SMMDD- SMD code</p>	<p><b>3ac</b></p>  <p>Data code (Y-year, W-week)</p> <p>SMD code</p>
<p><b>3ad</b></p>  <p>SMD-code</p>	<p><b>3ae</b></p>  <p>SMD-code</p>	<p><b>3af</b></p>  <p>SMD-code</p>	<p><b>3ag</b></p>  <p>Manufacturer logo</p> <p>SMD code</p>
<p><b>3ah</b></p>  <p>Manufacturer logo</p> <p>SMD code</p>	<p><b>3ai</b></p>  <p>Manufacturer logo</p> <p>SMD code</p>	<p><b>3aj</b></p>  <p>Manufacturer logo</p> <p>SMD code</p>	<p><b>3b</b></p>  <p>SMD-code Data code (Y-year, M-month)</p>
<p><b>3ba</b></p>  <p>SMD code Data code (Y-year, W-week)</p>	<p><b>3bb</b></p>  <p>SMD-code Data code (Month)</p>	<p><b>3bc</b></p>  <p>Internal ID code</p> <p>SMD code Data code (Y-year)</p>	<p><b>3bd</b></p>  <p>SMD code Week code</p>
<p><b>3be</b></p>  <p>Internal ID code</p> <p>SMD code Data code (Y-year, W-week)</p>	<p><b>3bf</b></p>  <p>Internal ID code</p> <p>SMD code Data code (Y-year, M-month)</p>	<p><b>3bg</b></p>  <p>SMD-code Data code (YY-year)</p>	<p><b>3bh</b></p>  <p>SMD code Data code (WW-week)</p>
<p><b>3bi</b></p>  <p>SMD code Data code (Y-year, W-week)</p>	<p><b>3bj</b></p>  <p>Green package</p> <p>SMD code Data code (Y-year, W-week)</p>	<p><b>3c</b></p>  <p>SMD code Data code (Y-year, M-month)</p>	<p><b>3ca</b></p>  <p>SMD code Data code (M-month)</p>

**SECTION 5**  
**3-pin cases SMD-code attribute**

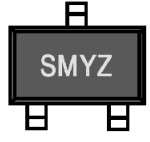
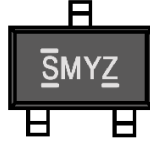
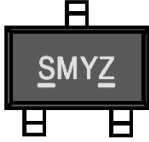
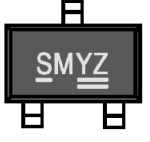
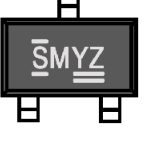
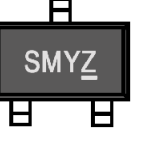
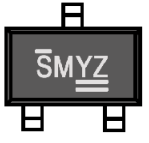
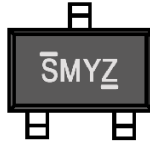
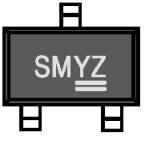
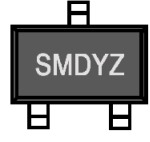
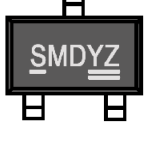
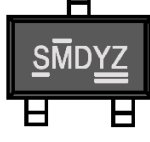
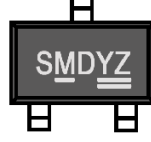
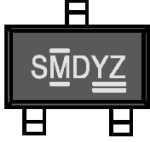
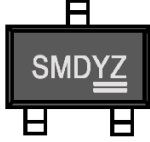
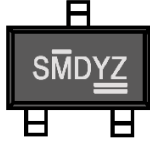
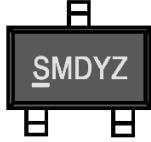
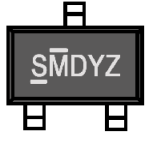
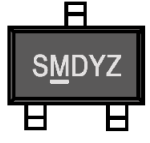
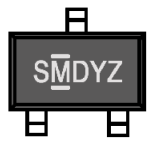

<p style="text-align: center; color: red;">B01</p> 	<p style="text-align: center; color: red;">B02</p> 	<p style="text-align: center; color: red;">B02a</p> 	<p style="text-align: center; color: red;">B04</p> 
<p style="text-align: center; color: red;">B04a</p> 	<p style="text-align: center; color: red;">B04b</p> 	<p style="text-align: center; color: red;">B04c</p> 	<p style="text-align: center; color: red;">B04d</p> 
<p style="text-align: center; color: red;">B04e</p> 	<p style="text-align: center; color: red;">B04f</p> 	<p style="text-align: center; color: red;">B04g</p> 	<p style="text-align: center; color: red;">B04h</p> 
<p style="text-align: center; color: red;">B05</p> 	<p style="text-align: center; color: red;">B05a</p> 	<p style="text-align: center; color: red;">B05b</p> 	<p style="text-align: center; color: red;">B05c</p> 
<p style="text-align: center; color: red;">B05d</p> 	<p style="text-align: center; color: red;">B05e</p> 	<p style="text-align: center; color: red;">B05f</p> 	<p style="text-align: center; color: red;">B05g</p> 
<p style="text-align: center; color: red;">B05h</p> 	<p style="text-align: center; color: red;">B05i</p> 	<p style="text-align: center; color: red;">B05j</p> 	<p style="text-align: center; color: red;">B05k</p> 

**SECTION 6**

**Additional production data info**





Besides SMD code, the manufacturers can place additional information such as **internal production lot number**, **traceability code**, **data of production**, **assembly location** etc. The additional info is an arbitral position and arbitral content (depending of the manufacturer) and can be alphanumeric symbol (symbols) or graphic symbol.

Below we present some additional info.

### Lot number.

Manufacturer: **Elm (ELM Technology Corporation):**

**Rules 1 (for ODO voltage detectors)**

Symbol 1 - A to Z(I, O, X excepted)

Symbol 2 - 0 to 9

**Rules 2 (for PPO voltage detectors)**

Symbol 1 - 0 to 9

Symbol 2 - A to Z(I, O, X excepted)

Manufacturer: **Tor (Torex Semiconductor LTD):**

01~09, 0A~0Z, 11~9Z, A1~A9, AA~AZ, B1~ZZ repeated,  
(G, I, J, O, Q, W excluded.) \* No character inversion used.

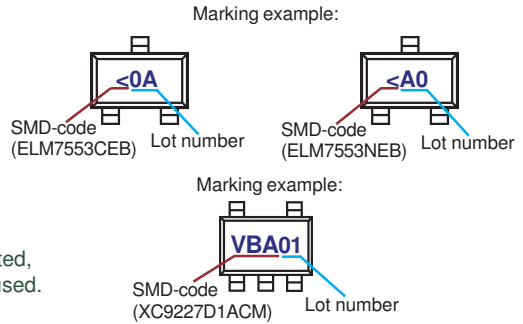

### Production data

Manufacturer: **Anw (Anwell Semiconductor Corp.)**

Dot above product code: Lot Code:

1		•	17	•		•
2		•	18	•		•
3		•	19	•		•
4		•	20	•		•
5		•	21	•		•
6		•	22	•		•
7		•	23	•		•
8		•	24	•		•
9		•	25	•		•
10		•	26	•		•
11		•	27	•		•
12		•	28	•		•
13		•	29	•		•
14		•	30	•		•
15		•	31	•		•
16		•				

Dot under product code: Year Code:

2003			
2004			•
2005		•	•
2006		•	•
2007		•	
2008		•	•
2009		•	•
2010		•	•

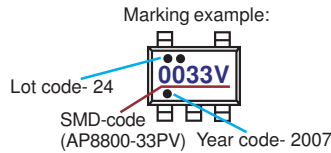

Manufacturer: **Ape (Advanced Power Electronics Corp.)**

**Code Year**

**YY** 2004, 2008, 2012

**YY** 2003, 2007, 2011

**YY** 2002, 2006, 2010

**YY** 2001, 2005, 2009

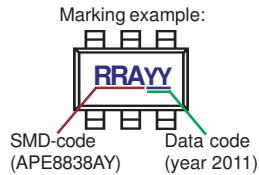

Manufacturer: **Axl (AXElite Technology Co., Ltd)**

**Code Year Code Week**

**7** 2007 **A...Z** 1...26

**8** 2008 **a...z** 27...52

**9** 2009

**A** 2010

**B** 2011

**C** 2012

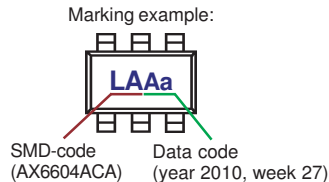









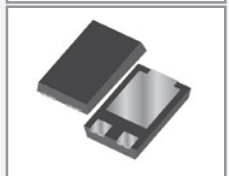
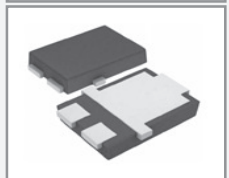
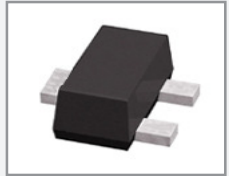
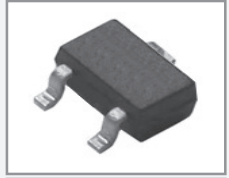



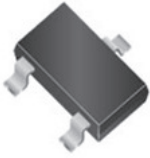







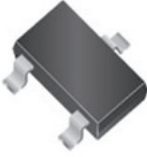

Manufacturer: **Di (Diodes Inc.)**

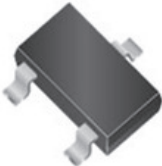
Y : Year : 0~9XXX

W : Week : A~Z : 1~26 week; a~z : 27~52 week; z represents 52 and 53 week

**SECTION 7**  
Case drawings

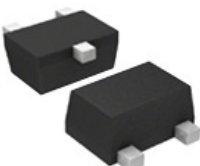
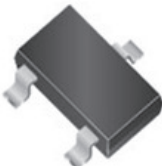

 1-1Q1A 2-1L1A	 1-2S1A 1-2S1B 1-2S1C	 2-1B1A	 2-1E1A
 2-2H1A 2-2H1B	 2-2HA1A	 2-2U1A	 2-3S1A
 3-LLMM	 3MM	 3-TUSMM	 3-USMM
 2025 CP CPH3	 CMPAK CPA MCP3	 EM3 Mini3-G1 Minit3-F1 SC-59A	 EMT3
 EMT3F F5T MCPH3	 ESM SON1408-3	 fSM SOT-1123 SOT-923	 MCP MPAK SC-75 SC-75A
 MCPAK	 NMini3-R1-B	 SC-59 SMT3	 SC-70 SC-70-3 SC-70-3L

**SECTION 8**  
**Sample schematic diagram**



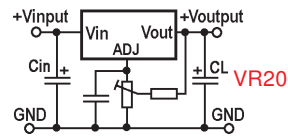
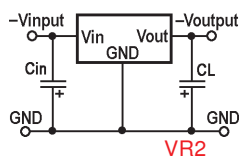
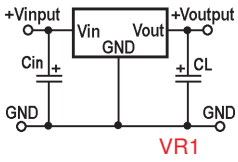
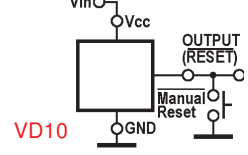
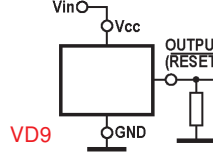
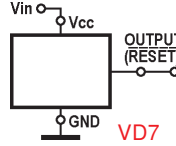
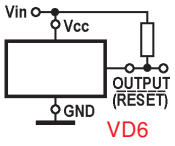
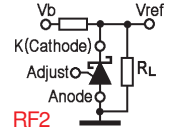
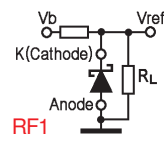
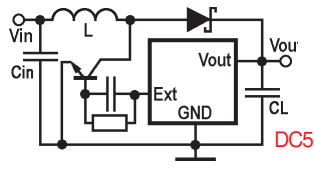
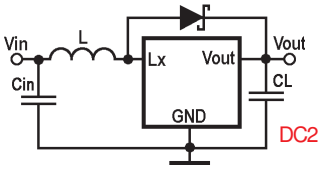



**SECTION 9**  
**Manufacturers name, logo and web page URL**





**Aat- Advanced Analog Technology**  
<http://www.aatech.com.tw/index.aspx>



**AbI- ABLIC Inc.**  
<https://www.ablicinc.com/en/semicon/>



**Ad- Analog Devices**  
<http://www.analog.com>



**Adt- ADDtek**  
<http://www.addmtek.com/Index.htm>



**Afs- Analog Future Chip Co., Ltd.**  
<http://www.afsemi.com/>



**Agi- Agilent Technologies**  
[www.semiconductor.agilent.com](http://www.semiconductor.agilent.com)



**Aic- Analog Integrations Corporation**  
<http://www.analog.com.tw>



**Ali- Alliance Semiconductor**  
<http://www.alsc.com>



**All- Allegro MicroSystems Inc.**  
<http://www.allegromicro.com>



**Alt- Aolittel Technology Co., Ltd**  
<http://www.aolittel.com>



**Ame- AME, Inc.**  
[www.ame.com.tw](http://www.ame.com.tw)



**Ams- AMOS Technology Limited**  
<http://www.amos-tech.com>



**Amz- Amazing Microelectronic**  
<http://www.amazingIC.com>



**Ana- Anachip Corp.**  
[www.anachip.com.tw](http://www.anachip.com.tw)



**Anb- Anbon Semiconductor Co., Ltd.**  
<http://www.anbonsemi.com>



**Anp- Anpec Electronics Corp.**  
[www.anpec.com.tw](http://www.anpec.com.tw)



**Ans- AnaSem Inc.**  
<http://www.anasem.net/>



**Ant- Advanced Analogic Technologies, Inc.**  
<http://www.analogictech.com>



**Anv- Anova Technologies Co. Ltd**  
<http://anova-semi.com/>



**Anw- Anwell Semiconductor Corp.**  
<http://www.ansc.com.tw/>



**Aom- Alpha & Omega Semiconductor**  
<http://www.aosmd.com/>



**Yea-** Yeashin.Technology Co., Ltd  
<http://www.yeashin.com/>



**Yen-** Yenyo Technology Co., Ltd.  
<http://www.yenyo.com.tw/>



**Ynt-** Yint Electronics Co., Ltd.  
<http://www.yint.com.cn>



**Zbo-** Zibo Micro Commercial Components Corp.  
<http://www.zbmcc.com/en/>



**Zbs-** Zhide Electronics Co., Ltd  
<http://www.senocn.com/>



**Zhd-** Zibo Seno Electronic Engineering Co., Ltd.  
<http://www.cz-zhide.com/>



**Zlg-** Zilog, Inc.  
<http://www.zilog.com/>



**Zow-** Zowie Technology Corporation  
<http://www.zowie.com.tw/>



**Zx-** Zetex plc.  
<http://www.zetex.com>





© 2024-2025 Copyright Eugeniu Turuta

© 2024-2025 Copyright Martin Turuta

Toronto, © 2024-2025 edition

Chisinau, © 2024-2025 edition